

# RI21

## LPG REDUCER

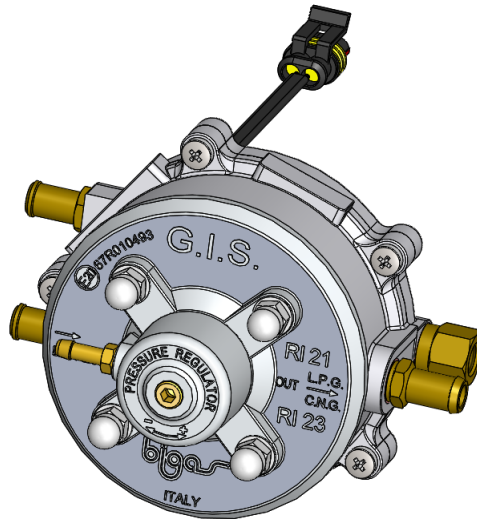

### INSTALLATION PROVISIONS & WARNINGS



**BIGAS INTERNATIONAL AUTOGAS SYSTEMS S.r.l.**

Via L. Becchetti, 4 - 25100 Bedizzole (BS) ITALY

Tel. +39 0554211275 - <http://www.bigas.it>

Emission: Bigas 07/2020 - ISWP016

Rev.02

## 1. DATA SHEET

<b>Manufacturer</b>	BIGAS INTERNATIONAL AUTOGAS SYSTEMS SRL	
<b>Gas type</b>	LPG	
<b>Model</b>	RI21	
<b>Engine maximum power</b>	140 KW (188 HP)	
<b>Max flow rate</b>	30.1 Kg/h (66.3 lb/h)	
<b>Gas inlet pressure</b>	30 bar (max.) (435 psi)	
<b>Working pressure</b>	0.9 ÷ 1.8 bar (13 ÷ 26 psi) adjustable	
<b>Gas Inlet</b> • Female connection for pipes	M10x1 x pipe ø6mm Brass	
<b>Gas outlet</b>	ø <sub>est</sub> 12mm /Brass	
<b>Vacuum union</b>	ø <sub>est</sub> 5 mm /Brass	
<b>Inlet/outlet cooling liquid</b>	ø <sub>est</sub> 10mm (n°2) Brass	
<b>Working temperature</b>	-20° ÷ 120°C (-4°C ÷ 248°F)	
<b>Fixing screw</b>	M8 x 1,25 mm	
<b>Overall dimension</b>	153X120X105 mm (6.0X4.7X4.1 inch)	
<b>Weight</b>	0,9 Kg (2,0 lbs)	
<b>Approval</b>	E20 67R-01 0493	

## 2. GENERAL DESCRIPTION

Before the installation, check that the component has been supplied with all the necessary accessories provided in the package, as listed below (see pic. 1):

Cod.	Description	Q.ty
<b>RIDGB210300</b>	LPG Reducer RI21	<b>1 pc</b>
	Fixing bracket - 165X30 mm	<b>1 pc</b>
	Accessories bag (Nipples, bicone, nuts, washer, "T" fitting, etc...)	<b>1 pc</b>
	Final testing certificate	

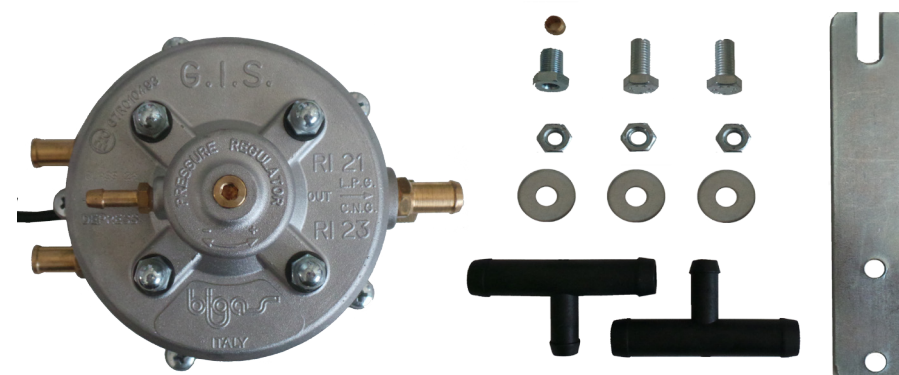

**Pic. 1** - Complete RI21 reducer with supplied accessories, picture for illustrative purpose

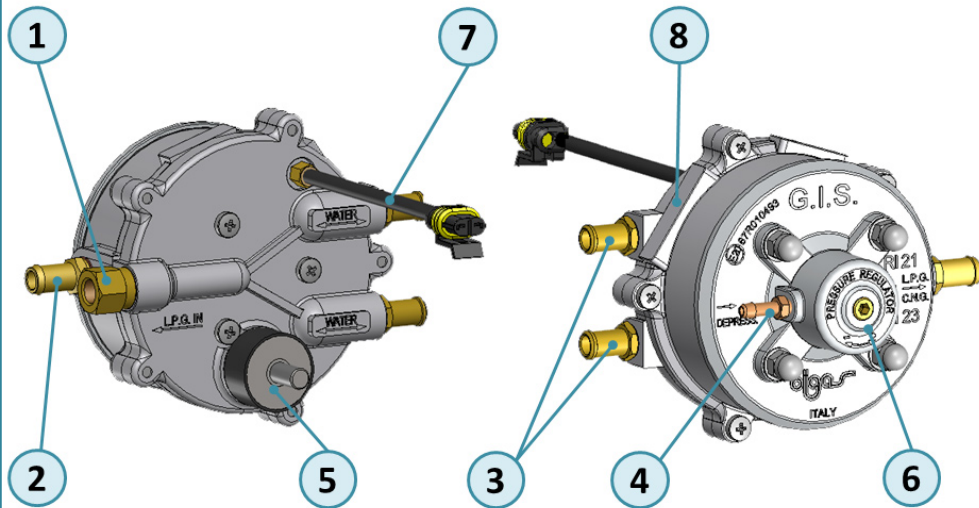

	Description
1	Gas inlet fitting
2	Gas outlet fitting
3	Water inlet/outlet fitting
4	Vacuum union
5	Threaded fixing pin
6	Pressure adjusting screw
7	AMP Super Seal connector
8	Pressure reducer serial number

## 3. PROVISIONS & WARNINGS

### 3.1 Reducer installation



Never connect the pressure reducer directly to the engine or to the engine components.



Do not install the pressure reducer to the bulkhead which separates the engine compartment from the vehicle.



When the engine is running, verify that the pressure reducer does not hit any other device.

Using the bracket provided, fix the pressure reducer by the threaded pin (6) with Silent Block system to the car body, in order to avoid vibration to the pressure reducer while it is working. Bracket can be bent or directed as needed.



Place the pressure reducer always in a lower position than the height of the cooling liquid expansion tank, in order to prevent air bubbles which may form in the water circuit.

### 3.2 Piping connections

For all kind of pipes the installer has to observe the following rules:

During the vehicle running there should be no movements that generate friction and usury of the pipes with other devices of the engine compartment (i.e. against sharp edges or moving parts like drive belts).

Pipes should not be stretched, nor shall have sharp corners that could create dangerous restrictions.



Carefully clean the High Pressure pipes before they are finally connected to the pressure reducer to prevent any residue getting inside it.

Do not leave any rubber parts during the cutting of the pipe. The presence of residues of burrs and chips inside the pipes could compromise the correct functioning of the system. Before installing the rubber hoses is a good practice to blow compressed air inside them.

Do not use for fastening pipes sealant products, such as: glues, silicones, mastic, etc ...

## 3.3 Gas pipes / Air hoses



The connection pipe from pressure reducer to the filter should be as short as possible.

Connect the high pressure gas pipe to the reducer gas inlet fitting **(1)** and secure it with a torque wrench for a proper tightening; subsequently verify that the clamp guarantees tightness.

Connect the rubber low pressure gas pipe on the gas outlet connection **(2)** and secure them with a clamp; subsequently verify that clamp guarantees tightness.

Using the rubber pipe, connect the vacuum union **(4)** to the intake manifold and secure them with a clamp.

## 3.4 Water hoses

Connect the rubber hose to the pressure reducer, fixing them on the inlet/outlet water connectors **(3)** and secure it with clamps.

While engine running, verify the clamps tightening and that no leakage is coming from water pipes.

The water cooling circuit connections of the pressure reducer can be installed in series or in parallel respecting to the heating circuit of the vehicle.

## 3.5 Electrical wiring

Connect the AMP - Super Seal **(7)** to LPG ECU.

## 3.6 Pressure reducer adjusting

To optimize the reducer operation use the pressure adjusting screw **(6)** with hexagon socket **(pic. 2)**.

To decrease the gas pressure, screw clockwise the screw **(6)** on the cover of the pressure reducer. To increase the gas pressure, unscrew counter-clockwise the same screw.

*(Adjust the socket head screw with 5/32" hex allen wrench)*

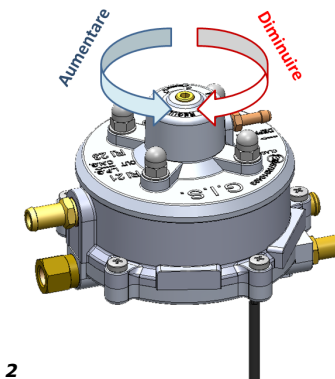

**Pic. 2**

## 3.7 Maintenance plan

Bigas recommends to provide a routine maintenance on the RI21 every 90,000 Kms, in order to prevent possible malfunctions and to verify its status.

Bigas highlights the importance of doing a check-in and a service on the above mentioned party in order to prevent possible malfunctions not connected to the product quality.



**BIGAS INTERNATIONAL AUTOGAS SYSTEMS S.r.l.**

Via L. Becchetti, 4 - 25100 Bedizzole (BS) ITALY

Tel. +39 0554211275 - <http://www.bigas.it>

Emission: Bigas 07/2020 - ISWP016

Rev.02