

EN

THREE PHASE HIGH VOLTAGE HYBRID INVERTER

N3-HV Series

User Manual

V08



- N3-HV-5.0
- N3-HV-6.0
- N3-HV-8.0
- N3-HV-10.0-A
- N3-HV-10.0

RENAC

Content

1. About this manual	4
1.1 Applicability.....	4
1.2 Target group	4
1.3 Symbols used.....	4
1.4 Acronyms and abbreviations.....	4
2. Safety	5
2.1 General Safety.....	5
2.2 Important safety instructions	5
2.3 Explanation of symbols	6
3. Introduction	7
3.1 Electrical system design	7
3.2 Basic features	7
3.3 Work modes	8
3.4 Dimensions	12
3.5 Ports.....	12
3.6 Technical data	13
4. Installation	15
4.1 Unpacking	15
4.2 Preparation for installation.....	17
4.2.1 Installation tools	17
4.2.2 Protective tools	17
4.2.3 Required cables.....	17
4.3 Installation precaution	18
4.4 Space requirement	19
4.5 Installation steps	20
5. Electrical connection	21
5.1 System Connection Diagrams	21
5.2 Grounding connection.....	22
5.3 PV Connection	22
5.4 Battery Connection	23
5.5 AC Output Connection	28
5.6 Communication connection	29
5.7 Relay connection	37
5.8 ATS connection (Optional)	38
6. LED indicator status and operation button	39
7. Commissioning	40
7.1 Check before powering on	40
7.2 Power on	40
7.3 Power off.....	41
8. Parallel system	41
8.1 System introduction	41

8.2 Work modes	42
8.3 Communication connection	43
8.4 LCD setting.....	43
9. Operation and handing	44
9.1 Menu structure.....	44
9.2 Operation	46
9.2.1 Main screen.....	46
9.2.2 Status	46
9.2.3 History	47
9.2.4 Settings	47
9.2.5 System Switch.....	54
9.2.6 About	55
9.2.7 Self-Test in accordance with CEI 0-21 (Applies to Italy only)	55
10. Troubleshooting	56
11. Decommissioning.....	60
11.1 Dismantling	60
11.2 Packing	60
11.3 Storage.....	60
11.4 Disposal.....	60
12. Appendix A.....	61
13. Appendix B.....	62

Notice

This manual contains important safety instructions, installation, electrical connections, commissioning, maintenance, and troubleshooting of the equipment.

Save the manual!

This manual must be stored carefully and be available at all times.

Copyright Declaration

All rights to the content of this manual are owned by RENAC Power Technology Co., Ltd. (hereinafter called as 'RENAC Power'). Any corporation or individual should not plagiarize, partially or fully copy it, and reproduce or distribute it in any form or means without prior written permission from RENAC Power.

RENAC Power reserves the right of final interpretation. This manual may be updated according to user's or customer's feedback. The information in this manual is subject to change without notice. Every effort has been made to ensure the accuracy of the contents of this manual, but nothing mentioned herein expresses or implies any other information. Please check our website at <http://www.renacpower.com> for latest version.

1. About this manual

1.1 Applicability





Please read the product manual carefully before installation, operation or maintenance. This manual contains important safety instructions and installation instructions that must be followed during installation and maintenance of the equipment.

1.2 Target group

This manual is intended for technical professionals for installation, commissioning and maintenance of the hybrid inverter. The technical personnel has to be familiar with the product, local standards, and electric systems.

1.3 Symbols used

The following types of safety instructions and general information appear in this document as described below:

	<p>'Danger' indicates a hazard with a high level of risk that, if not avoided, will result in death or serious injury.</p>
	<p>'Warning' indicates a hazard with a medium level of risk that, if not avoided, will result in death or serious injury.</p>
	<p>'Caution' indicates a hazard with a low level of risk that, if not avoided, could result in minor or moderate injury.</p>
	<p>'Notice' indicates a situation that, if not avoided, could result in equipment or property damage or provides tips that are valuable for the optimal operation of your product.</p>

1.4 Acronyms and abbreviations

ADD	Additional
BAT	Battery
EMI	Electromagnetic interference
EPS	Emergency power supply
LED	Light emitting diode
MPP	Maximum power point
MPPT	Maximum power point tracking
OLED	Organic light-emitting diode
PV	Photovoltaic
THDi	Total harmonic distortion

2. Safety

2.1 General Safety

The hybrid inverter has been designed and tested strictly according to international safety regulations. Read all safety instructions carefully prior to any work and observe them at all times when working on or with the hybrid inverter. Incorrect operation or work may cause:

- ◆ Injury or death to the operator or a third party;
- ◆ Damage to the inverter or other properties.

2.2 Important safety instructions

DANGER

- PV modules will produce electrical power when exposed to sunlight and can cause lethal voltage and electric shock.
- Only qualified personnel should work on PV modules.
- Do not open lid when the inverter is operating. Unauthorized opening will void warranty and warranty claims and in most cases terminate the operating license.
- When lid is opened, live components will be exposed, touching these may result in death or serious injury.
- Operating damaged inverter can lead to hazardous situations that can result in death or serious injuries due to electric shock.
- Batteries store large amounts of electrical energy. Short-circuiting or incorrect installation may lead to burns or serious injuries.
- Lethal voltages are present at battery terminals and cables connecting to the inverter. Severe injuries or death may occur if the cables and terminals are touched.
- PV negative (PV-) and battery negative (BAT-) on inverter side are not grounded intentionally. Connecting PV- or BAT- to EARTH is strictly forbidden.

WARNING

- Do not disconnect PV, AC or battery plugs and cables while the inverter is operating. Before working on the system power down on all supplies and wait for 5 minutes to discharge. Verify that there is no voltage or current before disconnecting any plugs or cables.
- Use personal protective equipment, including rubber gloves and protective boots during installation or maintenance.

CAUTION

- Do not touch any hot parts such as the heat sink during operation, temperature of inverter surface may exceed 60°C during operation.
- Electrical installation and maintenance must only be carried out by trained and qualified electrician, following all local regulations.
- Do not open inverter lid or change components without RENAC Power's authorization. Unauthorized work will invalidate warranty.
- Operate inverter as explained in this manual, failure will damage equipment and invalidate warranty.

NOTICE

Installation and maintenance must be carried out by competent electricians following all local regulations. With an integrated universal current-sensitive residual current monitoring unit included the inverter will disconnect immediately from the mains power once a fault current with a value exceeding the limit is detected. However, if an external residual current device (RCD) is mandatory, the switch must be triggered at a residual current of 300 mA (recommended), or it can be set to other values according to local regulations. For example, in Australia, the inverter can use an additional 100mA (type A) RCD in installations.

When installing, operating, and maintaining the product, comply with local laws and regulations. The safety instructions in this manual are only supplements and cannot cover all the precautions.









Renac will not be held liable for any damage caused by violating general safety operation requirements, general safety standards, or any safety instruction in this manual.

Anti-Islanding Effect

Islanding is a condition when grid connected PV / batteries back feed energy into the Grid when Grid is turned off for maintenance work, putting maintenance personal at serious risk. N3-HV series inverters prevent islanding through Active Frequency Drift (AFD).

2.3 Explanation of symbols

Symbols on the type label:

Symbol	Explanation
	CE mark. The inverter complies with requirements of applicable CE guide-lines.
	Beware of hot surface. The inverter can be hot during operation. Avoid touching during operation.
	Danger of high voltage. Danger to life due to high voltage in the inverter!
	Danger. Risk of electric shock!
	Inverter should not be disposed of with the household waste. Disposal information can be found in this manual.
	Don't work on this inverter until it is isolated from battery, mains supply and on-site PV modules.
	Danger to life due to high voltage. Inverter holds stored energy, wait for 5 minutes to discharge before opening lid.
	Please read this manual before installation.
	RCM (Regulatory Compliance Mark) The product meets the requirements of the applicable Australian standards.

3. Introduction

3.1 Electrical system design

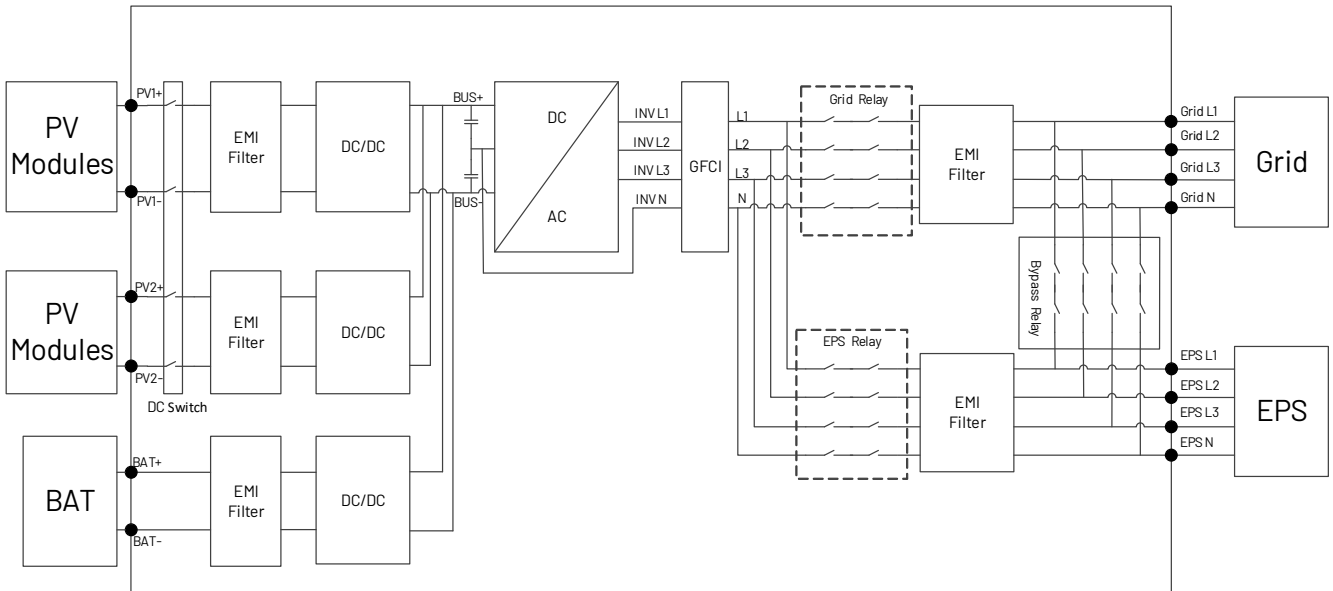

Figure 3-1 Block diagram of the N3-HV

3.2 Basic features

The N3-HV Series hybrid inverters are designed to work with PV modules, battery, mains supply and electrical loads. Hybrid inverter helps to optimize on-site consumption, charge battery with surplus PV energy and supply energy from battery to meet load. When PV and battery energy are insufficient, mains supply will be used to support loads.

Model name: **N3-HV-5.0**

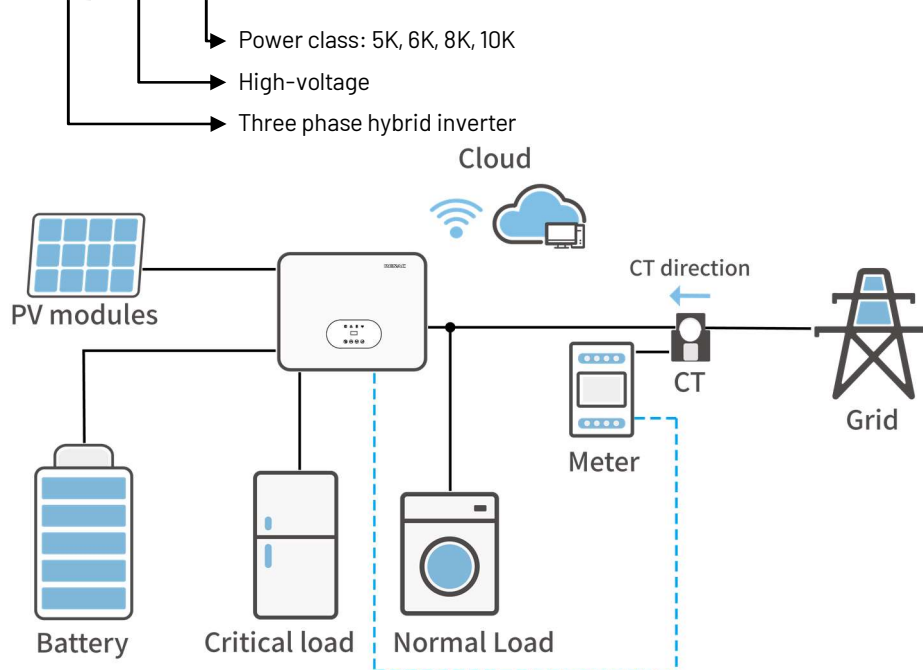

Figure 3-2 Basic application scenario

3.3 Work modes

The N3-HV Series hybrid inverter has the following work modes based on the configuration and connected equipment.

Work mode: Self Use

This mode is applicable to areas with low subsidies and high electricity prices. Self-consumption of PV renewable energy is the highest priority. Excess PV generation is used to charge batteries, and then feed back into the grid.

a. When the PV power is sufficient, PV power will supply the following sequence:

Consumption priority: Load -> Battery -> Grid

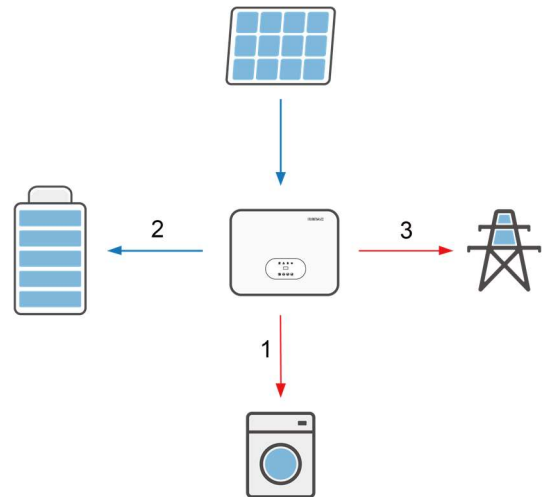

Figure 3-3

b. When the PV power is insufficient, the battery will discharge to supply loads, and the grid will join in if the battery power is not enough.

Supply priority: PV power -> Battery -> Grid

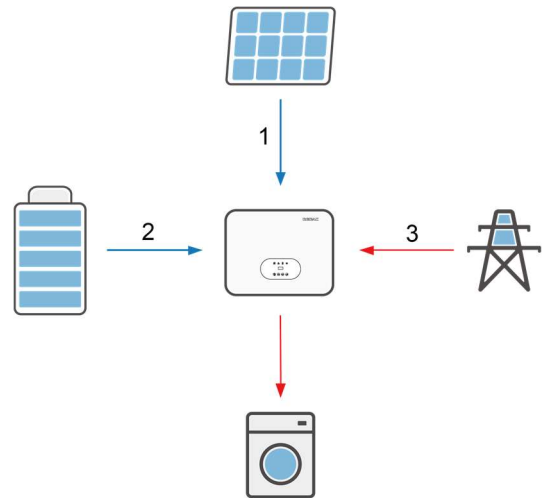

Figure 3-4

Work mode: Time of Use

Applicable to the areas with large gaps between peak and valley electricity prices. Users can set time-based schedules to charge the battery by App or inverter display.

- a. During charging time period inverter will use the power from PV or grid to charge the battery.
Consumption priority: Battery -> Load

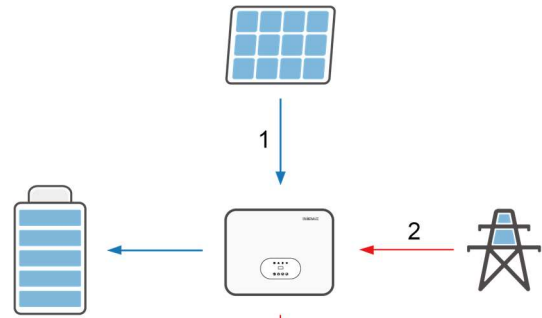

Figure 3-5

- b. Outside the charging time period inverter will work in self use mode. Using the power from PV and battery to supply loads and the insufficient part will be supplied by the grid.
Supply priority: PV power -> Battery -> Grid

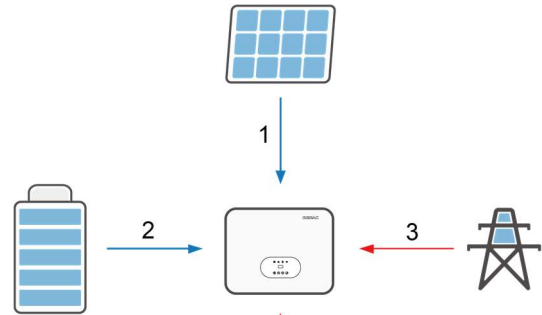

Figure 3-6

Work mode: Backup Use

It is suitable for the areas with frequent power outages. When the grid is off, the battery is used as backup power to supply load. This mode ensures that the battery will have enough energy to supply loads during a grid outage. PV and battery could support the backup load in the event of a blackout.

- a. When grid is on, the battery will be in charging state during the charging time period and will not be discharged.

Consumption priority: Battery -> Load

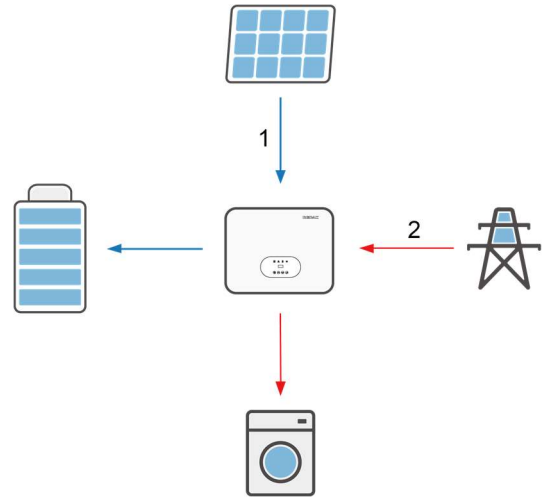

- b. When grid is off, the battery will be discharged to supply load. The inverter will connect grid automatically when grid goes back on.

Supply priority: PV power -> Battery

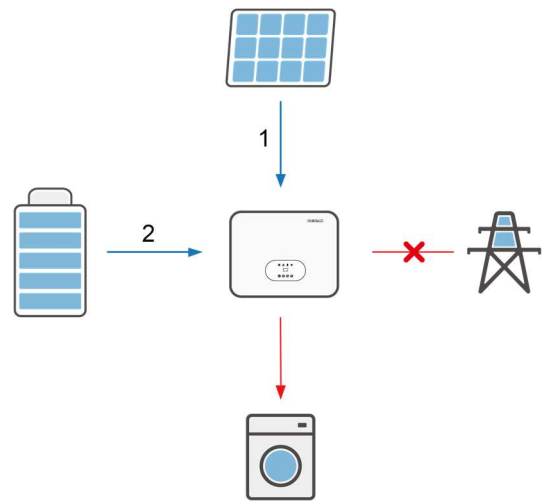

Work mode: Feed in Use

This mode applies to the area that has high feed-in tariff and export control. This model prioritizes grid feeds with sufficient PV power to maximize the tariff subsidy earned.

- a. When the PV power is sufficient, the PV generation will supply load first, then feed into grid, and the excess power will charge the battery last.

Consumption priority: Load -> Grid -> Battery

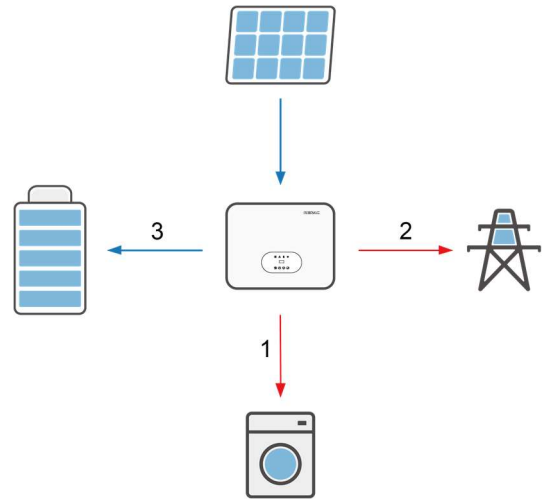

Figure 3-9

- b. When the PV power is insufficient, using the power from PV and battery to supply loads and the insufficient part will be supplied by the grid.

Supply priority: PV power -> Battery -> Grid

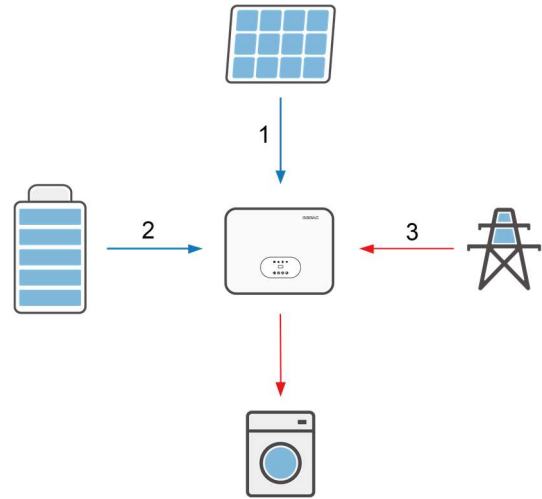

Figure 3-10

WARNING

Ensure that the load powered is within EPS's discharge power limit, failure will result in inverter shut down with 'Over Load' warning.

When 'over load' error is displayed, adjust load to make sure it is within the range of the EPS output, and turn inverter back on.

For nonlinear load, do pay attention to inrush power, make sure it is within the range of the EPS output.

3.4 Dimensions

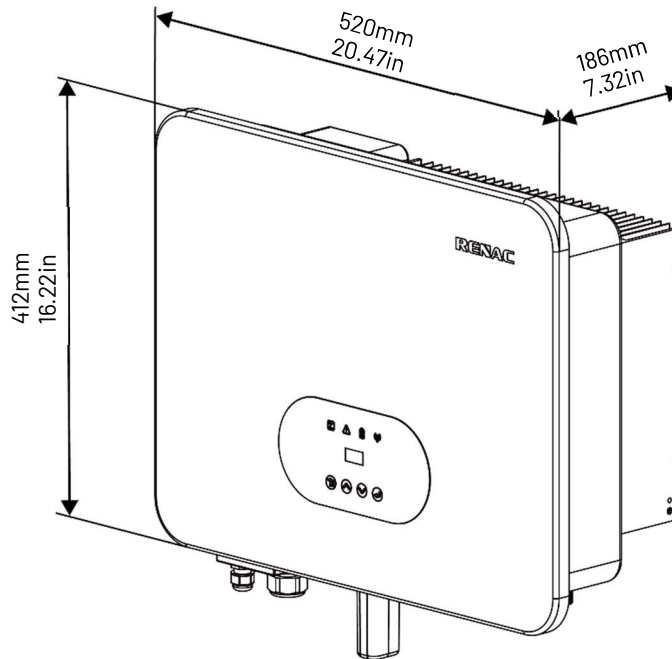

Figure 3-11 Dimensions of N3-HV

3.5 Ports

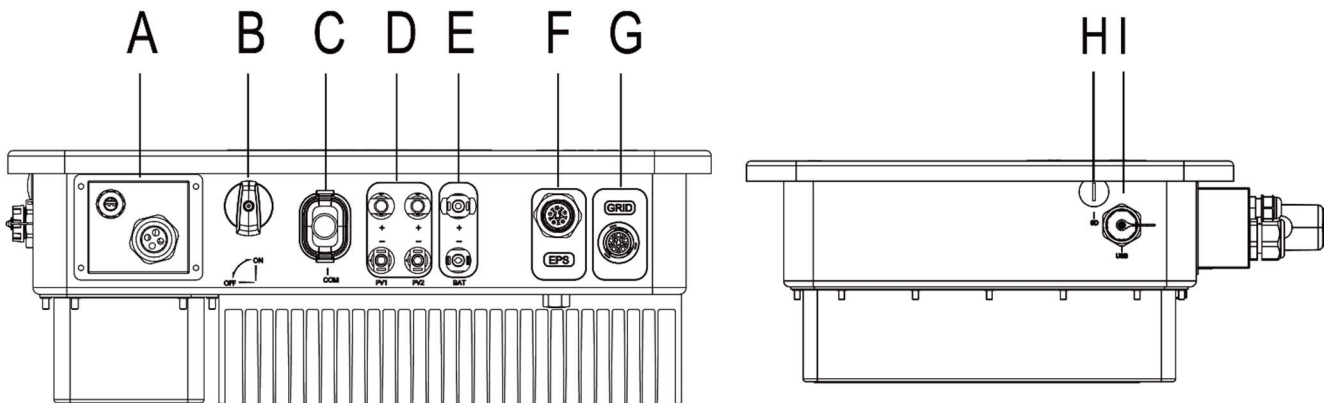

Figure 3-12 Terminals of the inverter

Object	Description	Object	Description
A	Communication port	F	EPS port
B	DC switch	G	Grid port
C	WIFI or 4G or Ethernet port	H	SD port (Reserve)
D	PV connectors	I	USB port
E	Battery connectors		

3.6 Technical data

Model	N3-HV-5.0	N3-HV-6.0	N3-HV-8.0	N3-HV-10.0-A	N3-HV-10.0
PV Input Data					
Max. Recommended PV Power (W)	7500	9000	12000	15000	15000
Max. PV Input Voltage (V)	1000				
MPPT Voltage Range (V)	160 ~ 950				
Rated PV Input voltage (V)	600				
Start-up Voltage(V)	160				
No. of MPP Trackers	2				
No. of Input Strings per Tracker	1				
Max. DC Input Current (A)	18 / 18				
Max. Short Circuit Current(A)	23 / 23				
Back feed Current to Array(A)	0				
DC Switch	Integrated				
AC Output Data					
Maximum Apparent Power (VA)	5500	6600	8800	10000	11000
Rated AC Power (W)	5000	6000	8000	10000	10000
Maximum AC Current (A)	7.6	9.1	12.2	14.4	15.2
Rated AC Current (A)	7.2	8.7	11.5	14.4	14.4
Rated AC Voltage / Range (V)	3 / N / PE, 220 / 380, 230 / 400				
Grid Frequency / Range (Hz)	50 / 60; ± 5				
Adjustable Power Factor [cos φ]	0.8 leading ~ 0.8 lagging				
Output THDi (@Rated Output) (%)	< 3				
AC Input Data					
Max. apparent AC Power (VA)	10000	12000	16000	20000	20000
Max. AC Current(A)	15.2	18.2	24.3	28.8	30.4
Rated AC Voltage / Range (V)	3 / N / PE, 220 / 380, 230 / 400				
Grid Frequency / Range (Hz)	50 / 60				
AC Inrush Current (A)	32				
Maximum Output Overcurrent Protection	40				
AC Maximum output fault current (A)	73				
Output DC(Battery)					
Battery Type	Lithium				
Battery Voltage Range (V)	160 ~ 700				
Max. Charging / Discharging Current (A)	30				
Communication Interface	CAN				
EPS Output (With Battery)					
EPS Rated Power (W)	5000	6000	8000	10000	10000
EPS Rated Voltage (V)	3 / N / PE, 220 / 380, 230 / 400				
EPS Rated Frequency (Hz)	50 / 60				
EPS Rated current (A)	7.6	9.1	12.2	14.4	15.2





Model	N3-HV-5.0	N3-HV-6.0	N3-HV-8.0	N3-HV-10.0-A	N3-HV-10.0
Output THDi (@Rated Output) (%)	< 3				
Automatic Switch Time (ms)	≤ 20				
Peak Apparent Power, Duration (VA, s)	7500, 60	9000, 60	12000, 60	15000, 60	15000, 60
Efficiency					
Max. Efficiency (%)	98.00%	98.00%	98.00%	98.00%	98.00%
Euro Efficiency (%)	97.70%	97.70%	97.70%	97.70%	97.70%
Max. Battery Discharge Efficiency (%)	97.60%	97.60%	97.60%	97.60%	97.60%
Protection					
DC Insulation Monitoring	Integrated				
Input Reverse Polarity Protection	Integrated				
Anti-island Protection	Integrated				
Residual Current Monitoring	Integrated				
Over-heat Protection	Integrated				
AC Overcurrent Protection	Integrated				
AC Short-circuit Protection	Integrated				
AC Overvoltage Protection	Integrated				
DC Surge Protection	Type II				
AC Surge Protection	Type II				
General Data					
Size (Width * Height * Depth mm)	520 * 412 * 186				
Weight (kg)	27				
User Interface	LED + OLED				
Communication	RS485 and USB (Standard), WIFI or 4G or Ethernet (Optional)				
Operating Temperature Range (°C)	-25 ~ +60				
Relative Humidity (%)	0% ~ 100%				
Operating Altitude (m)	≤ 2000				
Standby Self Consumption (W)	< 15				
Topology	Transformerless				
Pollution degree	III				
Protective class	I				
OVC categories	DC II / AC III				
Environmental categories	Outdoor				
Cooling	Natural				
Protection Grades	IP65				
Noise (dB)	< 35				
Warranty (years)	5				
Certifications & Standards					
Grid Regulation	VDE 4105, EN 50549-1, VDE 0126, CEI 0-21, EN 50549-GR, EN 50549-PL, TOR Erzeuger, EN50549-CZ, AS4777, UNE217002				
Safety Regulation	IEC 62109-1, IEC 62109-2				
EMC	EN/IEC 61000-6-1, EN/IEC 61000-6-3				

4. Installation

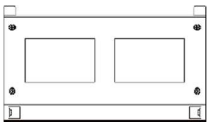
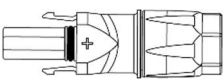
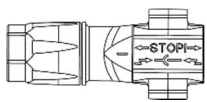
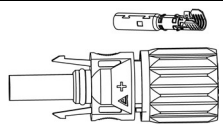
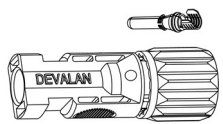
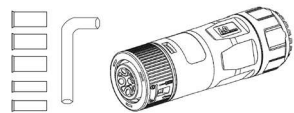
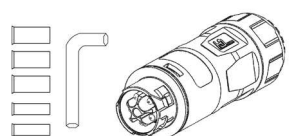
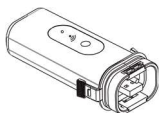
4.1 Unpacking

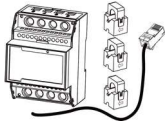
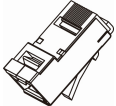
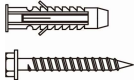
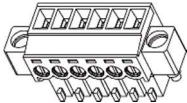
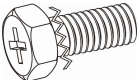





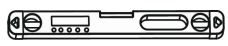
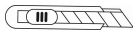

Before opening the package, please check whether the packing box is complete and whether there is any damage, soaked in water; if the package is incomplete or obviously damaged, please contact the supplier. If the package is complete, please open the box to check whether the contents are complete against the material list or as shown in the figure below; if there is any omission or damage, please contact the supplier.

No.	Shape	Model	Quantity
1		N3-HV inverter	1
2		Mounting bracket	1
3		Battery power cable terminal(+)	1
4		Battery power cable terminal(-)	1
5		PV cable terminal(+) with a corrugated pipe	2
6		PV cable terminal(-) with a corrugated pipe	2
7		GRID terminal & related accessories	1
8		EPS terminal & related accessories	1
9		WIFI or 4G or Ethernet Dongle (Optional)	1



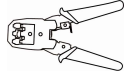
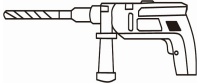
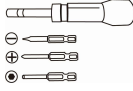
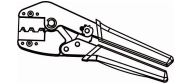

No.	Shape	Model	Quantity
10		Three phase smart meter & three CTs	1
11		RJ45 connector for COM cable	5
12		Expansion tube M6 & screw M6*55 for mounting bracket	4
13		8 PIN terminal	1
14		Ground screw M5*12	2
15		Ground OT terminal	1
16		Quality Certificate	1
17		User Manual	1

4.2 Preparation for installation

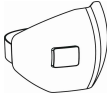

4.2.1 Installation tools



No.	Tool	Model	No.	Tool	Model
1		Spirit level	7		Knife
2		Wire stripper	8		Marker
3		Tube Terminal Crimping Pliers	9		Rubber hammer
4		Heat gun	10		RJ45 crimping tool
5		Hammer drill	11		Torque screwdriver
6		PV terminals crimping tool	12		Multimeter

4.2.2 Protective tools

No.	Tool	Model	No.	Tool	Model
1		Dust mask	4		Insulated shoes
2		Goggles	5		Safety helmet
3		Insulated gloves			

4.2.3 Required cables

No.	Tool	Model	Cross-section
1		PV cable	4 ~6 mm ²
2		Grounding cable	4 mm ²

No.	Tool	Model	Cross-section
3		Grid / EPS cable	4 ~ 6 mm ²
4		Network cable	Standard network cable
5		Signal cable	0.25 ~ 0.3 mm ²

4.3 Installation precaution

The N3-HV series inverter is designed for outdoor installation (IP65).

- Do not install inverter in direct sunlight.
- Do not mount inverter on flammable material.
- Do not install inverter in areas where flammable materials are stored.
- Do not install inverter in potentially explosive areas.
- Do not install inverter during rain or high humidity (>95%).
- Provide adequate ventilation when using batteries, and also read the warning label on the bottom of the inverter.
- Install inverter where air temperature would be below 40°C. Children should not have access to inverter.
- The inverter emits a slight noise when operating, this is normal and will not affect performance.
- Mounting should not tilt more than 5 degrees.
- The inverter is heavy, ensure the mounting is strong enough to hold the weight of the inverter.
- If installed in a cabinet, closet or other small enclosed areas, sufficient air circulation must be ensured in order to dissipate heat generated by the unit.
- Please select a concrete wall with load-bearing capacity and non-flammable surface for installation.

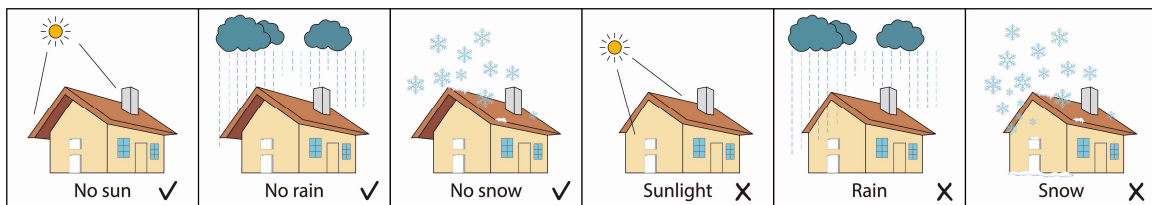

Figure 4-1 Installation environment

Lifting and Handling

The unit is heavy. Do not lift it alone.

- When lifting, ensure that the unit is firmly held to avoid risk of accidental tipping or dropping.
- Ensure that the method of lifting will not allow the unit to slip from chains, slings or turn-over from lifting devices.
- Transportation must be carried by qualified persons wearing necessary personal protection equipment.
- Do not walk or stand beneath or in the proximity of the load.
- Accessible for maintenance and repair work.
- Loading capacity and hardness of the supporting surface, load rating of mounting bracket should be at least four times the weight of the devices according to IEC62109-1. And supporting characteristics will be impaired by wear, corrosion, material fatigue or ageing. This should be calculated by inspection of the design data of supporting material and consulting construction engineer.

4.4 Space requirement

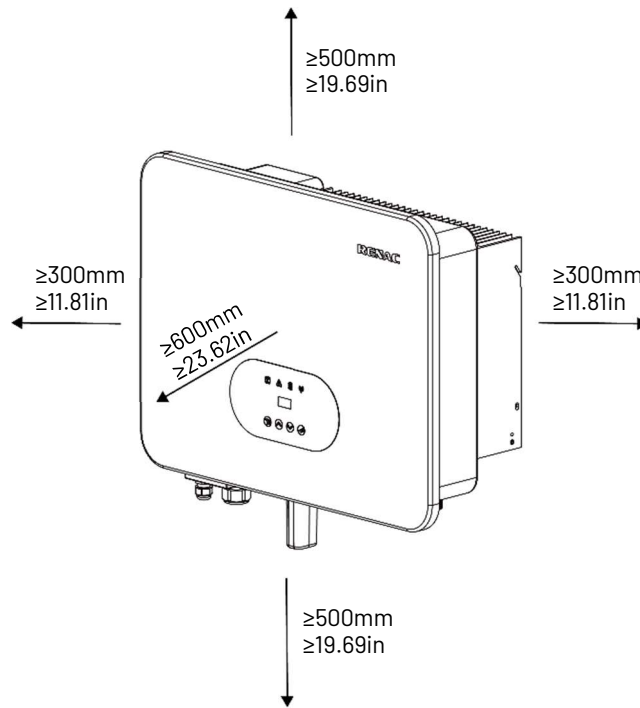

Figure 4-2 Installation space

Lifting and Handling

The unit is heavy. Do not lift it alone.

- When lifting, ensure that the unit is firmly held to avoid risk of accidental tipping or dropping.
- Ensure that the method of lifting will not allow the unit to slip from chains, slings or turn-over from lifting devices.
- Transportation must be carried by qualified persons wearing necessary personal protection equipment.
- Do not walk or stand beneath or in the proximity of the load.
- Accessible for maintenance and repair work.
- Loading capacity and hardness of the supporting surface, load rating of mounting bracket should be at least four times the weight of the devices according to IEC62109-1. And supporting characteristics will be impaired by wear, corrosion, material fatigue or ageing. This should be calculated by inspection of the design data of supporting material and consulting construction engineer.

4.5 Installation steps

1. Fix wall bracket on the wall.

- Use the wall bracket as a template to mark the position of the 4 holes.

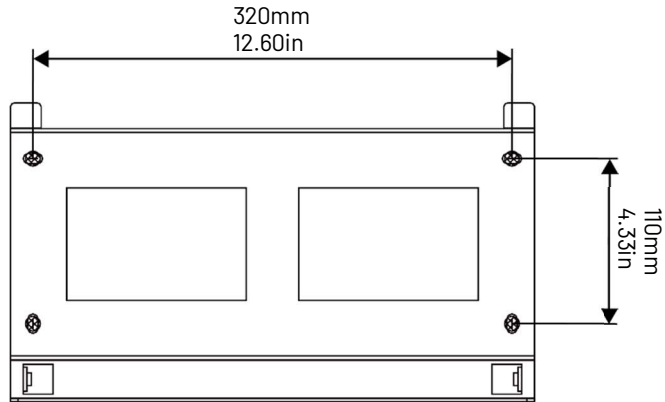

Figure 4-3

- Drill holes with $\Phi 10$ drill bit carefully, make sure the holes are deep enough (at least 45mm).
- Insert anchors fully into the holes. Install wall bracket using screws provided.

2. Hang the N3-HV inverter on the wall bracket.

Lifting inverter needs at least 2 people, use the handles at the sides of the inverter. To hang the inverter over the bracket, move the inverter close to it, slightly lower inverter making sure the 4 mounting bars on the back of the inverter is fixed well with 4 grooves on the bracket. Finally, tighten with M5*12 screws on the side of the unit.

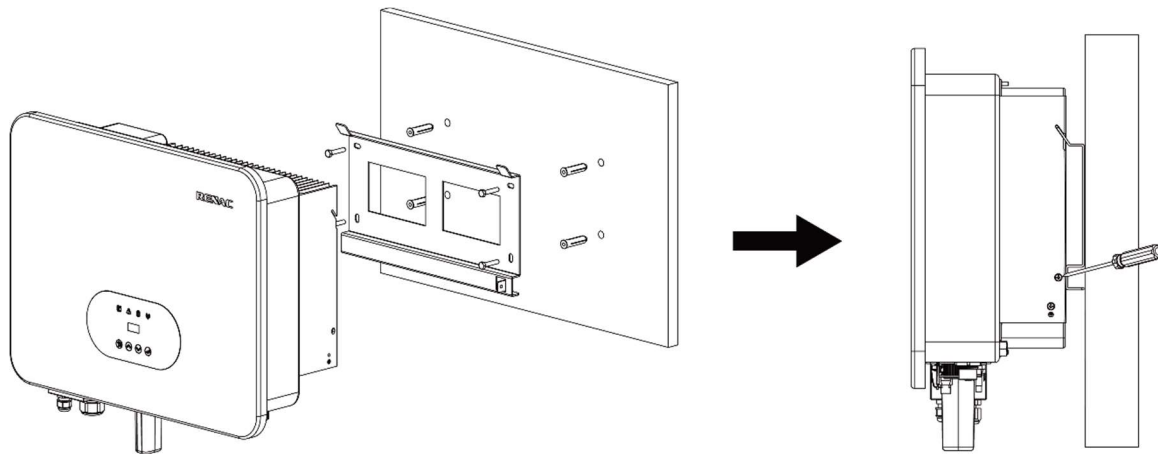

Figure 4-4

5. Electrical connection

5.1 System Connection Diagrams

(1) Diagram below is for grid system without special requirement.

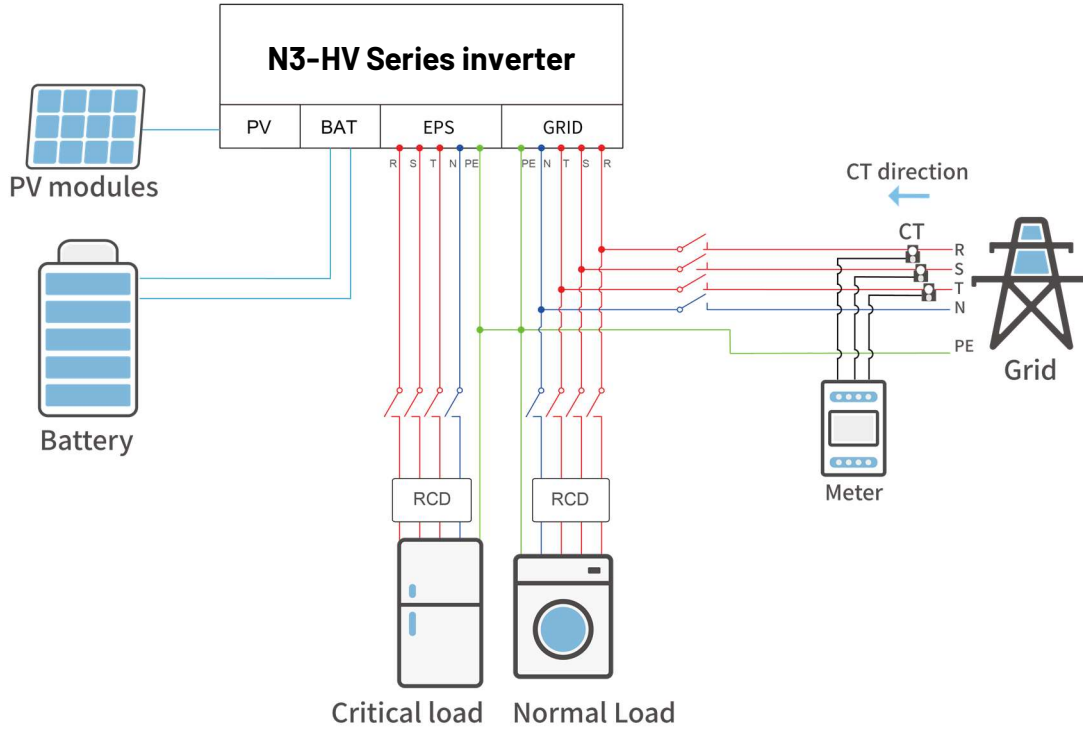

Figure 5-1

(2) Diagram below is for Australia, South Africa and New Zealand where neutral line can't be switched.

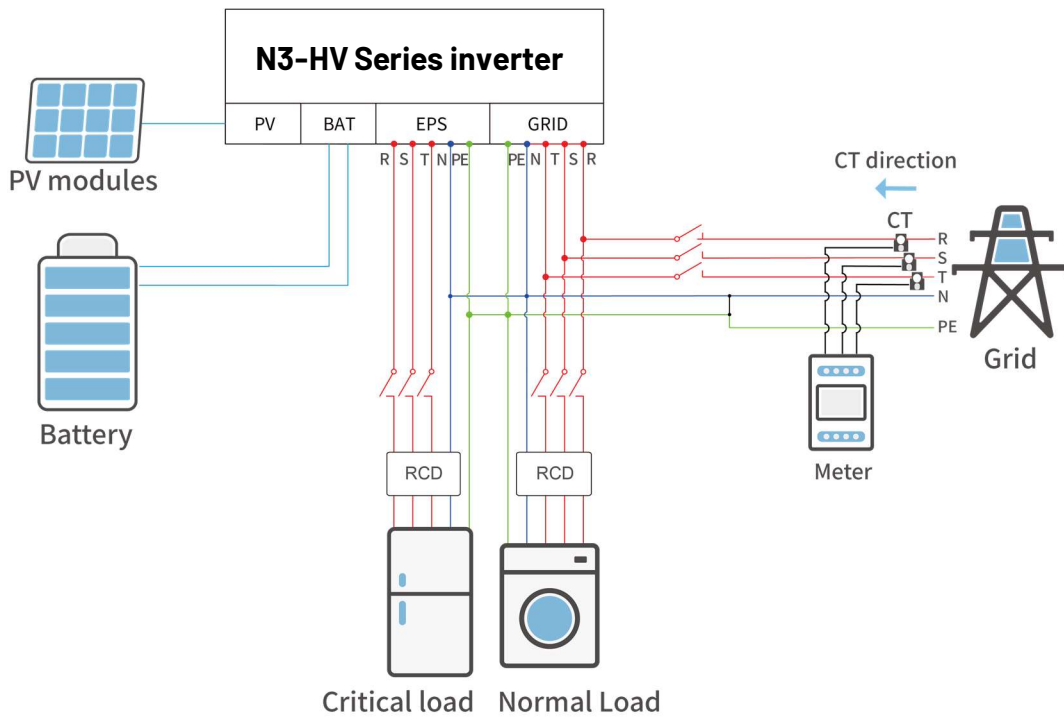

Figure 5-2

5.2 Grounding connection

1. Connect the grounding cable before connecting other cables. Users need to prepare their own grounding cable with a recommended cross-sectional area of 4mm².

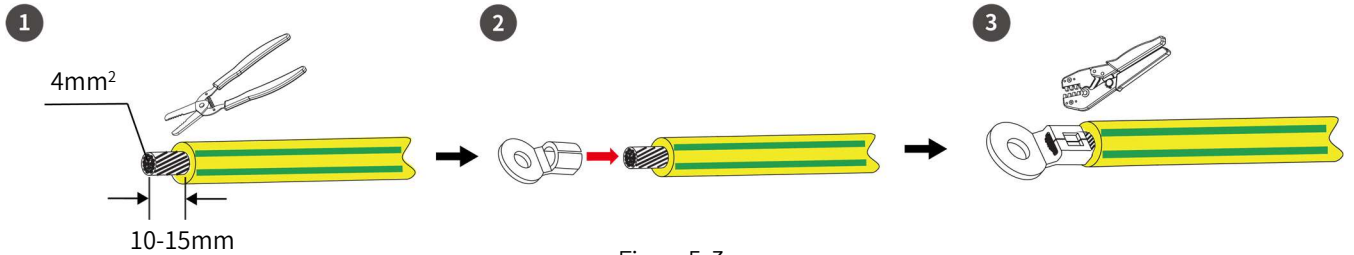

Figure 5-3

2. Connect the grounding cable at the inverter end.

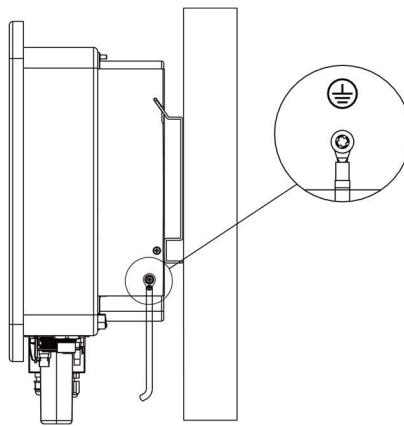

Figure 5-4

5.3 PV Connection

Before connecting PV modules to N3-HV Series hybrid inverter, ensure the following:

- The total short- circuit current of PV module must not exceed inverter’s maximum DC current.
- Make sure that open circuit voltage of PV module is less than 1000V.
- PV modules are not connected to earth/grounding conductor.
- Use the right PV plugs from accessory box, Battery plugs look similar to PV plugs, do confirm before using.



The inverter must only be operated with PV modules with class II protection in accordance with IEC 61730, application class A. It is not allowed for the positive pole or the negative pole of the PV modules to be grounded. This can cause the inverter to be destroyed.

Connection Steps:

1. Turn off the DC switch.
2. Prepare 4 ~ 6mm² PV cable and PV plugs as below.
3. Strip 7mm of the conductor with stripping plier. Use a suitable stripping tool for this (e.g. "PV-AZM-410").
4. Insert striped cable into pin contact and ensure all conductor strands are captured in the pin contact.

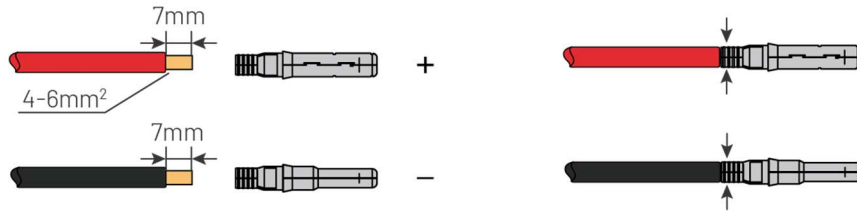

Figure 5-5

5. Crimp pin contact by using a crimping pliers (PV-CZM-22100). Put the pin contact with striped cable into the corresponding crimping pliers and crimp the contact.
6. Insert pin contact through the cable nut to assemble into back of the male or female plug. When clicked the pin contact assembly is seated correctly.
7. Tightening the DC connector.
 - a. Slide the cable nut towards the back shell.
 - b. Rotate the cable nut to secure the cable.

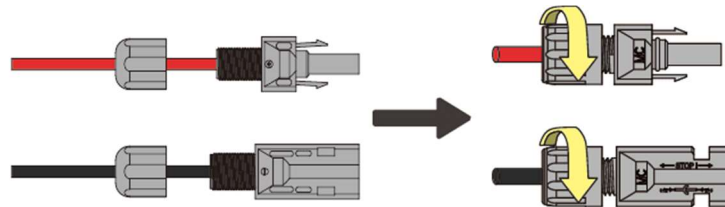



Figure 5-6





8. After securing the cable tightly, align the two half connectors and join together by hand until a 'click' is felt or heard.
9. To separate the DC connector.
 - a. Use the specified wrench tool.
 - b. To separate the DC+ connector, push tool down from upside.
 - c. To separate the DC- connector, push tool down from the bottom side.
 - d. Separate the connectors by hands.



5.4 Battery Connection

When building an on-site consumption storage system, high voltage battery is a necessary part. The N3-HV series inverter provides the necessary interfaces to connect the battery.

N3-HV series hybrid inverter is matched to the batteries of RENAC in the table below:

Model	N3-HV-5.0	N3-HV-6.0	N3-HV-8.0	N3-HV-10.0
TB-H1-7.48 	✓	✓	✓	✓

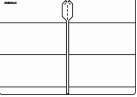
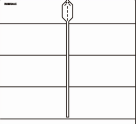
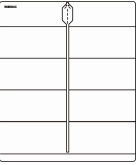
Model	N3-HV-5.0	N3-HV-6.0	N3-HV-8.0	N3-HV-10.0
TB-H1-11.23 	✓	✓	✓	✓
TB-H1-14.97 	✓	✓	✓	✓
TB-H1-18.7 	✓	✓	✓	✓
TB-H3-7.1 	✓	✓	✓	✓
TB-H3-9.5 	✓	✓	✓	✓

Model	N3-HV-5.0	N3-HV-6.0	N3-HV-8.0	N3-HV-10.0
TB-H4-10 	✓	✓	✓	✓
TB-H4-15 	✓	✓	✓	✓
TB-H4-20 	✓	✓	✓	✓
TB-H4-25 	✓	✓	✓	✓
TB-H4-30 	✓	✓	✓	✓



Make sure to select cables of the right specification. Failure could cause fire and result in death or serious injury.

Battery Power Cable Connection

1. Prepare tin-plated cables of conductor cross section of 4 to 6 mm².
2. Strip 15mm insulation off the conductor. Use a suitable stripping tool for this (e.g. "Knipex Solar 121211").
3. Open spring using a screwdriver (Figure 5-7).

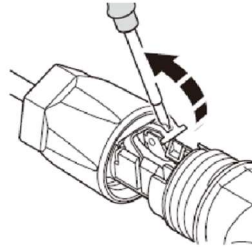

Figure 5-7

4. Carefully insert the stripped wire with twisted conductors all the way in (Figure 5-8, A). The litz wire ends have to be visible in the spring.
5. Close the spring. Make sure that the spring is snapped in (Figure 5-8, B).

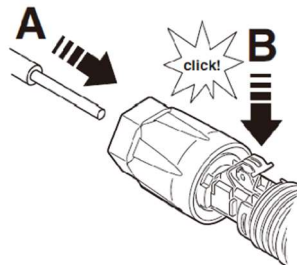

Figure 5-8

6. Push the insert into the sleeve (Figure 5-9, C).
7. Tighten the cable gland to 2 N.m (Figure 5-9, D). Use a suitable and calibrated torque wrench of size 15. Use an open-jaw wrench, size 16, to hold the connector in place.

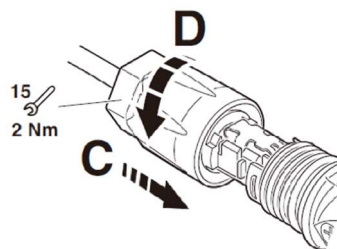

Figure 5-9

8. Fit the two connectors together until the connection audibly locks into place.
9. Check to make sure the connection is securely locked.

10. Separating connectors.

- 1). Insert the screwdriver into one of the four openings (Figure 5-10, A).
- 2). Leave the screwdriver in the opening. Pull the two connectors apart (Figure 5-10, B).

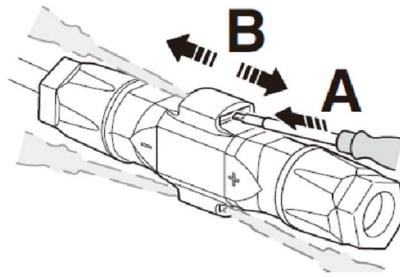

Figure 5-10

Battery Communication Connection:

The communication between battery and inverter is via CAN. The Pin definitions are as below.

RJ45 Connector

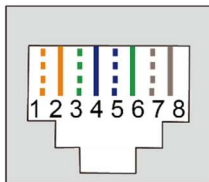

Figure 5-11

No.	Color	No.	Color
1	White- Orange	5	White- Blue
2	Orange	6	Green
3	White-Green	7	White-Brown
4	Blue	8	Brown

Pin	1	2	3	4	5	6	7	8
Function	NC	GND	NC	BMS_CANH	BMS_CANL	GND	BMS_485A	BMS_485B

Overview for all battery connections (take Turbo H3 for example):

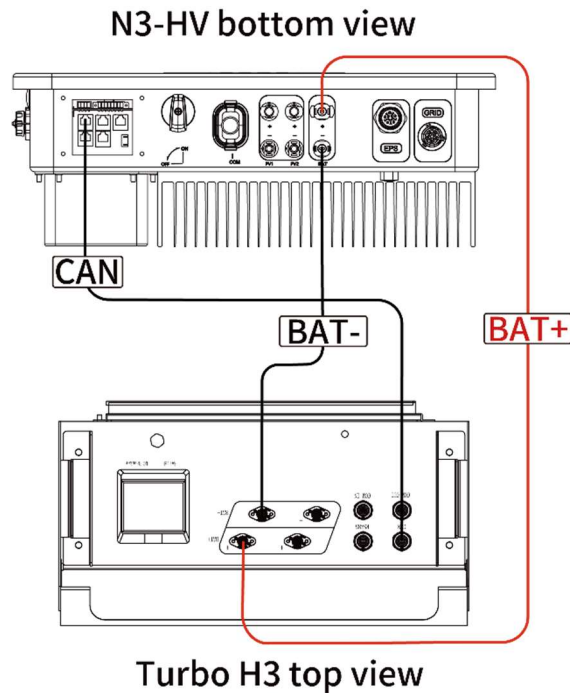

Figure 5-12

5.5 AC Output Connection

N3-HV series inverters have already integrated RCMU (residual current monitoring unit) inside, however if an external RCD is required, a type A RCD with rated residual current of 100mA or higher is recommended.

There are two AC terminals and the assembly steps for both are the same, just need to check one for 'Grid' another for 'EPS'. The AC cable and micro-breaker/external fuse specification for AC side of N3-HV series inverter as below.

Model	N3-HV-5.0	N3-HV-6.0	N3-HV-8.0	N3-HV-10.0-A	N3-HV-10.0
Cable(Cu)	4mm ²	4mm ²	4mm ²	4~6mm ²	4~6mm ²
Normal Load-Breaker or external fuse	10A	16A	16A	20A	20A
Grid-Breaker	20A	32A	32A	40A	40A



Select cables of the correct specifications.
 Failure could result in in fire and lead to death or serious injury.
 Don't connect the line/phase cable to 'PE' terminal, failure will result in improper operation of the inverter.

Connection Step:

- Strip about 15mm of the cable insulation with a wire stripper, and install the stripped AC cables to the crimp terminals.

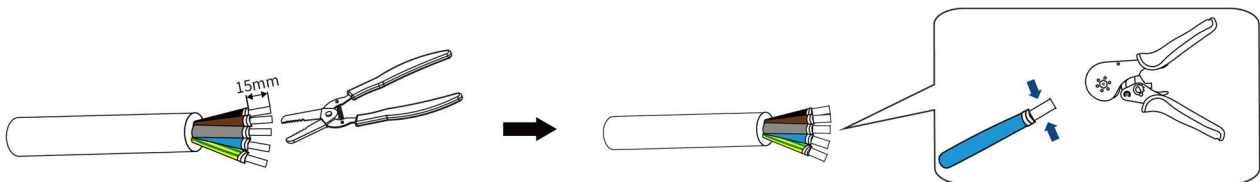

Figure 5-13

- Lead the AC cable through the cable gland and the housing.

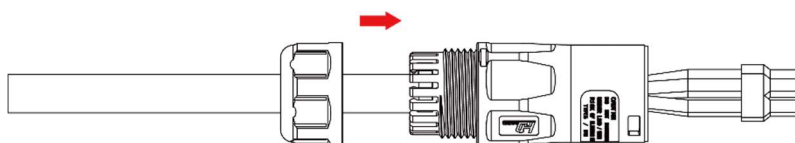

Figure 5-14

3. Fully insert the conductors to the corresponding terminal and tighten the screws to torque of 0.8 N.m. Pull cables outward to check whether they are firmly installed.

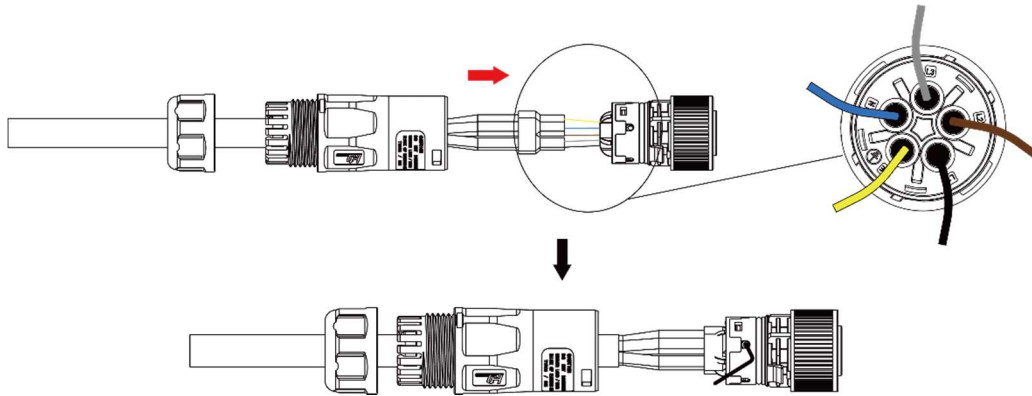

Figure 5-15

4. Assemble the housing, the terminal block and cable gland (torque 4 - 5 N.m). Make sure that the rib of the terminal block and the groove on the housing engage perfectly, with a click.

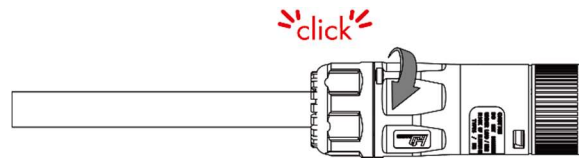

Figure 5-16

5.6 Communication connection

Communication interface

The inverter has a serial communication interface besides WIFI or 4G or Ethernet (optional). Dry contact, extended port, human and machine communication, etc., can be delivered to PC or other monitoring equipment via these interfaces.

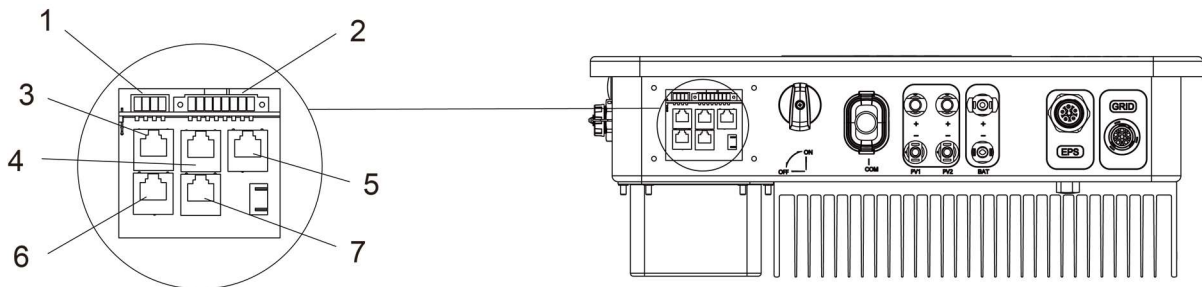

Figure 5-17 Communication interface

No.	Name	Description
1	RS485	Used for Modbus RTU communication with 3rd party external device or controller.
2	ADD interface	Used for RS485 communication of meter, generator control signals, shutdown signals and digital output.
3	BMS-CAN / 485	Used to communicate with the battery management system using CAN or RS485 communication protocol.
4	METER	Used for RS485 communication between inverter and the smart meter.

No.	Name	Description
5	DRM / RCR	This application meets the requirements of local Australian grid code (AS/NZS 4777.2), or for Germany Ripple Control Receiver (RCR) to convert the grid dispatching signal and send it as a dry contact signal.
6	Parallel port	For parallel connection of multiple hybrid inverters.
7	Parallel port	

1. RS485 Interface

RS485 interface PINS definition:

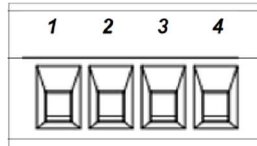

Figure 5-18

Pin	1	2	3	4
Function	+5V	GND	485A	485B

2. ADD Interface

ADD interface PINS definition:

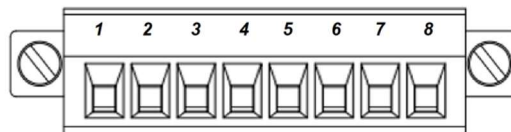

Figure 5-19

Pin	1	2	3	4	5	6	7	8
Function	METER-485A	METER-485B	GENA	GENB	+5V	SHUTDOWN	Relay	GND

Meter communication: METER_485A & METER_485B ---- Pin1 & Pin2

Relay contact output for generator: GENA & GENB ---- Pin3 & Pin4 (Reserve)

Shut down the hybrid inverter: +5V & SHUTDOWN ---- Pin5 & Pin6

Relay & GND --- Pin7 & Pin8

3. BMS-CAN / 485 port

RJ45 Connector

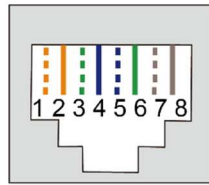

Figure 5-20

Pin	1	2	3	4	5	6	7	8
Function	NC	GND	NC	BMS_CANH	BMS_CANL	GND	BMS_485A	BMS_485B

4. METER

Meter port PINS definition:

RJ45 Connector

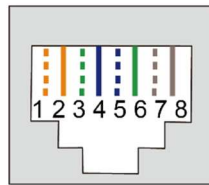



Figure 5-21

Pin	1	2	3	4	5	6	7	8
Function	METER-485A	METER-485B	NC	NC	NC	NC	NC	NC

The function of meter port same as Pin1 & Pin2 of ADD interface.

The N3-HV series hybrid inverter matches the meters shown in the table below:

Model	N3-HV-5.0	N3-HV-6.0	N3-HV-8.0	N3-HV-10.0
Eastron SDM630MCT 40mA 	√	√	√	√
Eastron SDM630Modbus V2 	○	○	○	○

"√" means standard.

"○" means optional.

(1) Meter wiring diagram for Typical Energy Storage System

The N3-HV series inverters can adopt two types of smart meters. One is our standard equipment, and the other is optional.

- Standard: EASTRON SDM630MCT(40mA) smart meter. The detailed connection line schematic can be found in Appendix A.

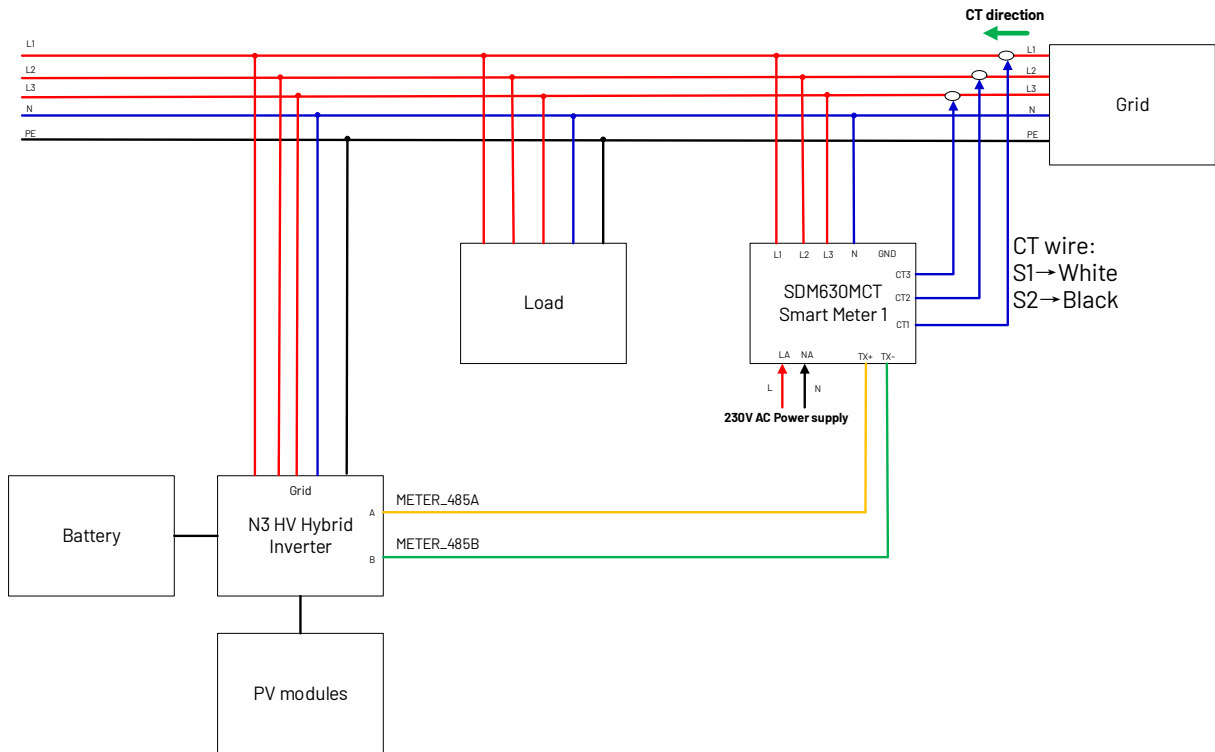

Figure 5-22

- Optional: EASTRON SDM630-ModbusV2 smart meter. The detailed connection line schematic can be found in Appendix B.

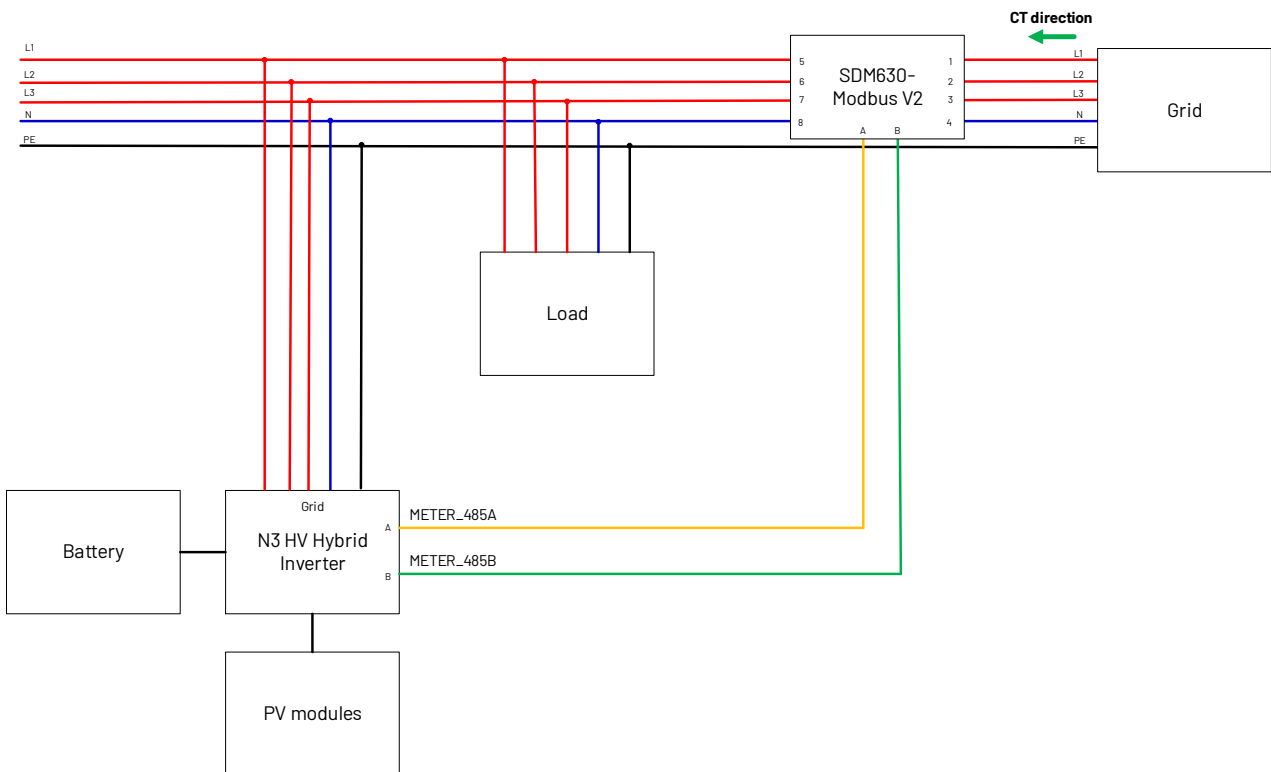

Figure 5-23

The connect steps are as follows:

- Connect the meter output "L1, L2, L3, N" to power Grid. And connect 230V AC power supply to "LA, NA" (LA –Grid L line, NA-Grid Neutral line).
- Connect the meter "TX+" "TX-" to inverter RS485 A and B of "MERER" (RJ45 PIN1 to METER_485A, RJ45 PIN2 to METER_485B).
- Connect meter CT1 to Grid L1, CT2 to Grid L2, CT3 to Grid L3. CT's white cable connects to S1 of the meter, and the black cable connects to S2. The CT direction must be facing to the load and inverter.

Note:

- 1) It is necessary to have the sequence of phases, CT1 must be connected to Grid phase line L1, CT2 must be connected to Grid phase line L2, CT3 must be connected to Grid phase line L3.
- 2) Please note that the CT direction must be facing to the load and inverter.
- 3) The local address and the meter address need to be set as "001" on the inverter screen. The address of the smart meter itself needs to be set to "001".

(2) Meter wiring diagram for AC Retrofit System

Renac Hybrid inverters can be used in the following situations also. If the site already has a grid tied PV system and want to increase module capacity or provide back-up power. Additional meter between the grid-connected inverters and N3-HV hybrid inverter is required. One N3-HV Hybrid inverter can be connected maximum two PV systems, and in the system, the smart meter must be the EASTRON SDM630MCT (40mA).

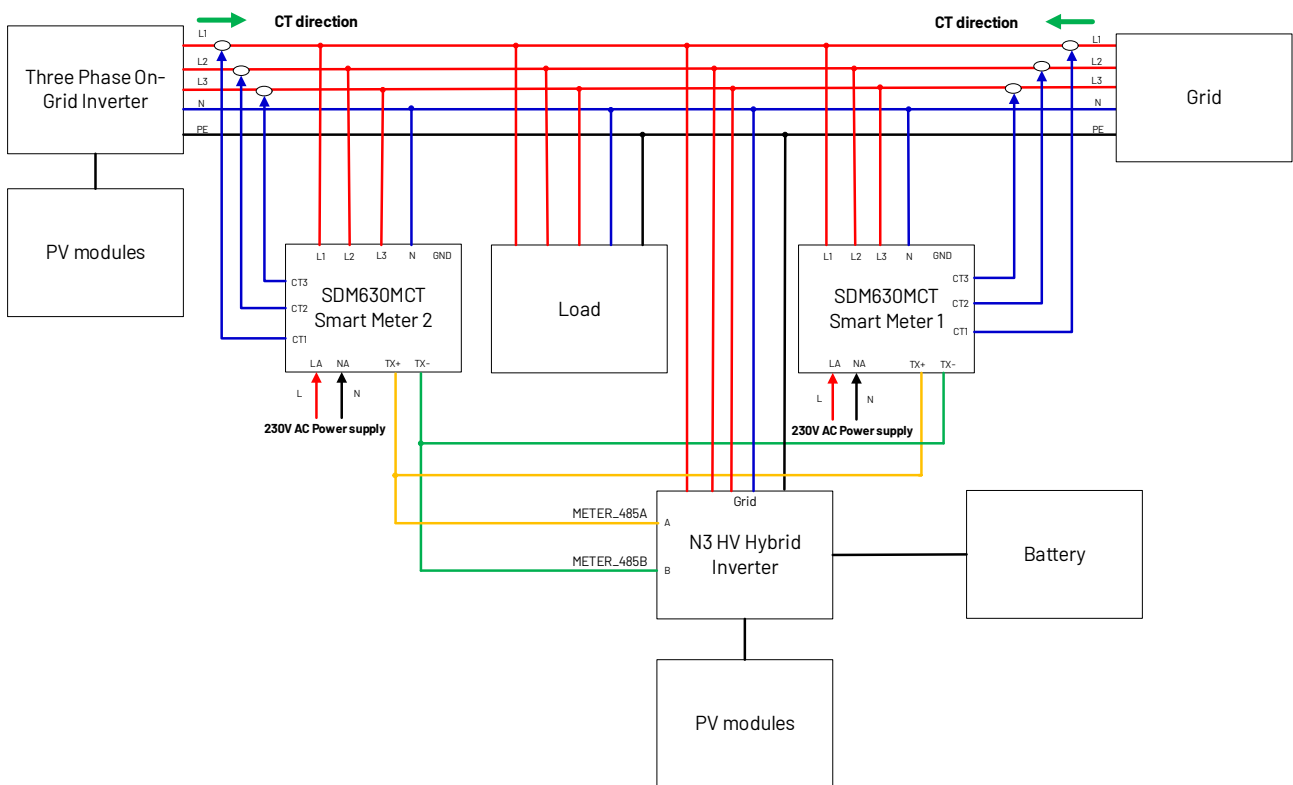

Figure 5-24 Connect one On-Grid three-phase inverter

The connect steps are the same as in the previous chapter.

Note: The smart meter communication cable "TX+" "TX-" can also be connected to "ADD Interface" port of inverter.

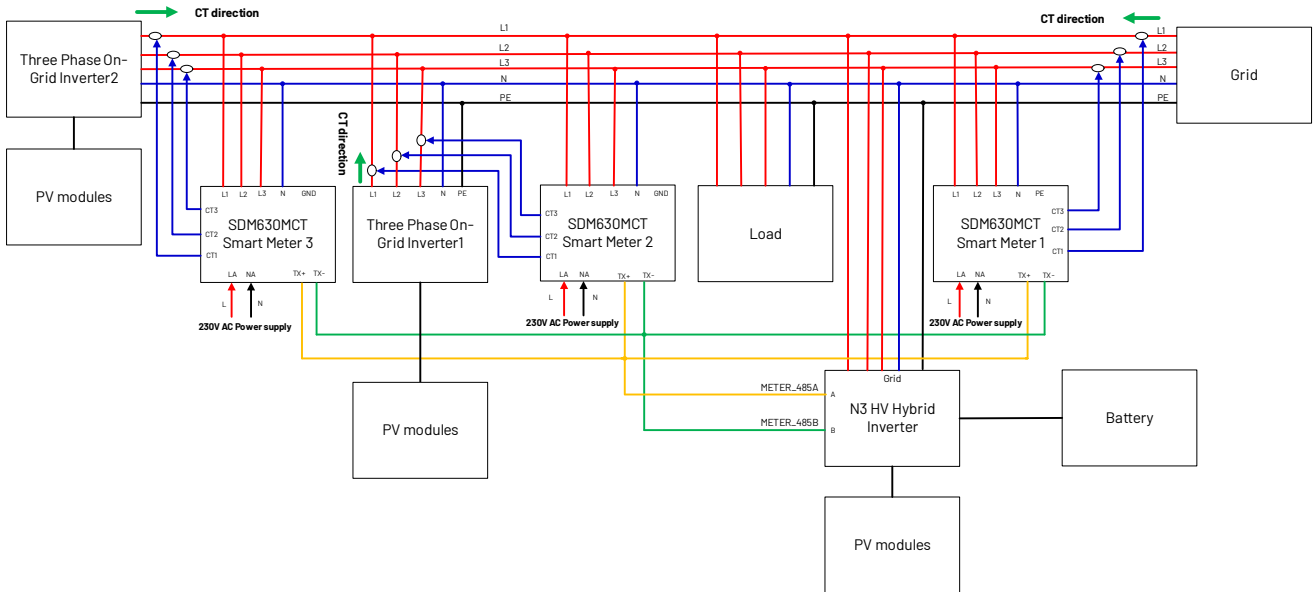
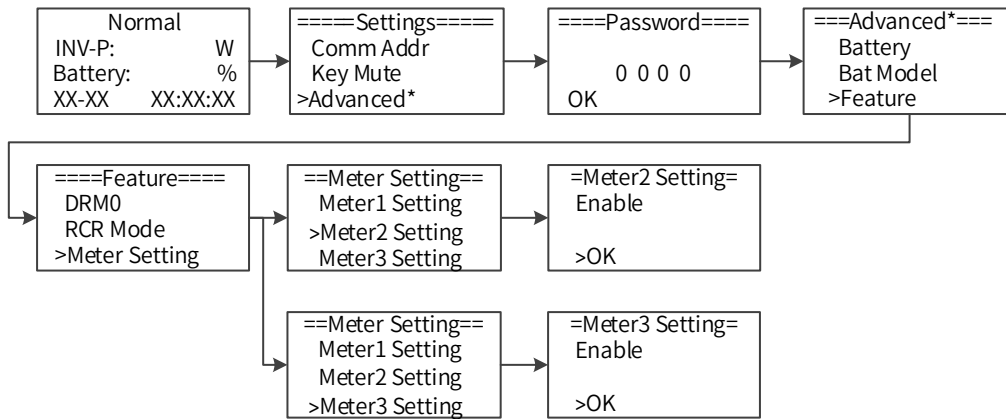

Figure 5-25 Connect two On-Grid three-phase inverters

Note:

- 1) It is necessary to have the sequence of phases, CT1 must be connected to Grid phase line L1, CT2 must be connected to Grid phase line L2, CT3 must be connected to Grid phase line L3.
- 2) Please note that the CT direction must be facing to the load and inverter.
- 3) The Smart Meter 2 and the Smart Meter 3 are turned off by default and need to be enabled before setting the meter address. Otherwise, the meter will not be able to communicate with the inverter. The setup steps are as follows.



- 4) Connect one On-Grid three-phase inverter(Figure 5-24): The local address needs to be set as "001" on the inverter screen, and meter1 address set as "001", meter2 address set as "002". The address of meter1 itself needs to be set to "001", and meter2 needs to be set to "002".
- 5) Connect two On-Grid three-phase inverters(Figure 5-25): The local address needs to be set as "001" on the inverter screen, and meter1 address set as "001", meter2 address set as "002", and meter3 address set as "003". The address of meter1 itself needs to be set to "001", meter2 needs to be set to "002", and meter3 needs to be set to "003".



If one chooses a flexible wire, ensure the cord section is pressed on the crimping terminal before connecting it to the meter as below.

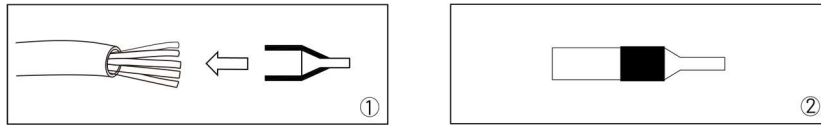

5. DRM/Ripple Control Receiver (RCR)

PINS definition:

RJ45 Connector

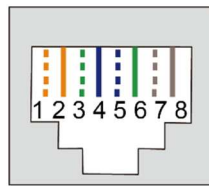

Figure 5-26

Pin	1	2	3	4	5	6	7	8
Function	DRM1/5	DRM2/6	DRM3/7	DRM4/8	+3.3V	COM/DRM0	GND	GND

This application meets the requirements of local Australian grid code (AS/NZS 4777.2) and Germany grid code (VDE-AR-N 4105).

a) In Australian grid code, requirements for connection call for compatibility with Demand Response Enabling Devices (DRED).

The DRED is controlled by a local network operator and allows to put the inverter in one of the Demand Response Modes (DRMs) defined by the standard:

- DRM 0 Operate the disconnection device.
- DRM 1 Do not consume power.
- DRM 2 Do not consume at more than 50% of rated power.
- DRM 3 Do not consume at more than 75% of rated power and source reactive power if capable.
- DRM 4 Increase power consumption (subject to constraints from other active DRMs).
- DRM 5 Do not generate power.
- DRM 6 Do not generate at more than 50% of rated power.
- DRM 7 Do not generate at more than 75% of rated power and sink reactive power if capable.
- DRM 8 Increase power generation (subject to constraints from other active DRMs).

Currently, it is mandatory to respond to DRM0, which allows the network manager to remotely decouple the installation from the distribution network.

b) In Germany grid code, this logic interface is for controlling and/or limiting the inverter's output power. The grid company uses the Ripple Control Receiver (RCR) to convert the grid dispatching signal and send it as a dry contact signal. The wiring of the ripple control receiver dry contact cables is shown in the figure below:

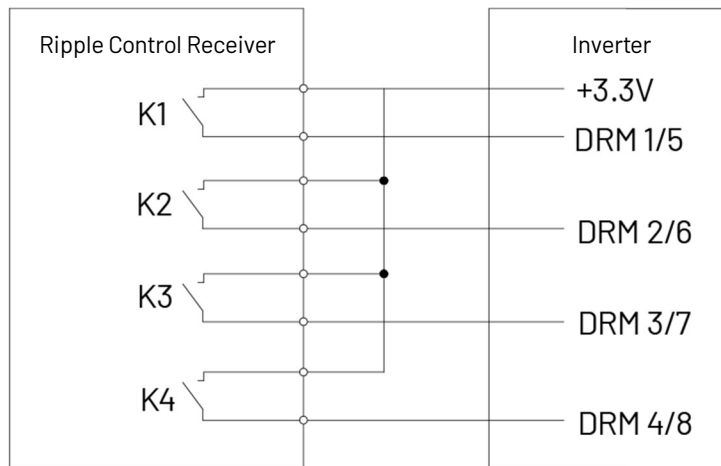

Figure 5-27

K1	K2	K3	K4	Switch Operation on External RCR	Output power (in % of the Rated AC output power)
1	0	0	0	Close K1	100%
0	1	0	0	Close K2	60%
0	0	1	0	Close K3	30%
0	0	0	1	Close K4	0%
Additional DIP settings				/	100%

c) According to the Germany EnWG (Energy Industry Act) 14a, all SteuVEs (controllable loads) need to be subject to emergency dimming by the grid. The grid operator can temporarily reduce the maximum grid-bought power consumption of controllable loads to 4.2 kW. If only need to use R4 EnWG 14a, other RCR ports no need to wire.

The inverter can limit the grid consumption as a percentage of its nominal output via the RCR input terminals.

There are two RCR Mode Selection. 3 Ports RCR/EnWG 14a, 3 RCR ports for limiting the power sell power %, and 4 RCR port (D4 EnWG 14a) for limiting buy power W (battery buy charging), defined as:

K1	K2	K3	K4	Output power	Input power
0	1	0	0	60%	Limitless
	0	1	0	30%	
	0	0	1	0%	
	Additional DIP settings			100%	
1	The DIP settings follow the above rules.			The output power follows the above rules.	Set value: Range (0,4200)W

6 / 7. Parallel port

PINS definition:

RJ45 Connector

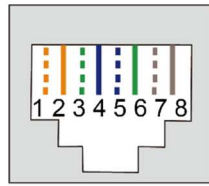

Figure 5-28

Pin	1	2	3	4	5	6	7	8
Function	RS485A	RS485B	VCC	CANH	CANL	GND	SYNA	SYNB

Note: Only 4 and 5 PIN pins are used. For specific parallel connection steps, please refer to Section 8 Parallel system.

5.7 Relay connection

In order to better control the load power consumption, a relay can control a contactor that will open or close in certain condition. Please choose a suitable contactor according to the +12VDC power supply by the inverter provided and field load power, e.g. the contactor types of the EATON-CR2020012. Please connect the contactor to the load and power grid according to the field conditions and connect the A1 and A2 of the contactor coil to the Pin7 and Pin8 of the ADD interface of the inverter.

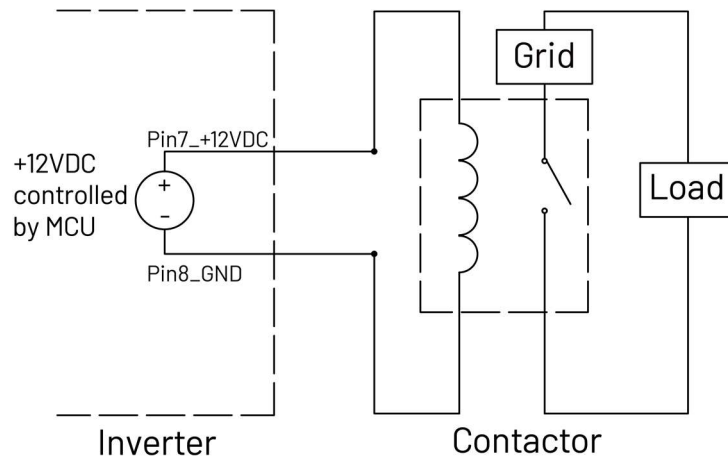

Figure 5-29 Relay function electrical block diagram

There are four function modes in total. See section 9.2.4 for specific settings.

1. Disable: Disable the relay function, and the load under the relay will always be out of power.
2. Manual On/Off: You can manually set the switch state of the relay.
3. Timing: The relay is on according to the setting relay switch-on start time, and it is off according to the setting relay switch-on end time. And it supports setting up to two time periods. (T1, T2).
4. Battery SOC: Under this mode, users need to set relay switch-on battery SOC, relay switch-off battery SOC delay off time.
 - RLY On BAT SOC: Relay is on if battery SOC exceeds a defined value.
 - RLY Off BAT SOC: Relay is off if battery SOC falls below a defined value.
 - Delay Off Time: The relay remains on if battery SOC falls below switch-on SOC for a defined time; the timer will reset if battery SOC exceeds switch-on SOC within a defined time. During the defined time, the relay will be off immediately if battery SOC has fallen below RLY Off BAT SOC.

5.8 ATS connection (Optional)

With the hybrid inverter not yet connected to the grid, the hybrid inverter will operate in EPS mode, utilizing the energy from the PV and the batteries to supply power to the loads. If, afterward, the user wants to connect the hybrid inverter to the grid, an external transfer switch is recommended; we recommend the NDQ2A-63 series automatic transfer switch. For maintenance purposes, the transfer switch is also an optional choice for installers; it will provide a power supply for loads when a hybrid inverter is under maintenance.

Automatic mode: The transfer switch automatically switches to supply power to the load depending on which side has power. Priority common power supply.

Manual mode: Users can switch the power supply by themselves according to the actual situation.

I: The load is powered from the Grid side;

II: The load is powered from the EPS side.

OFF: The load is vacant;

The system wiring diagram is shown below:

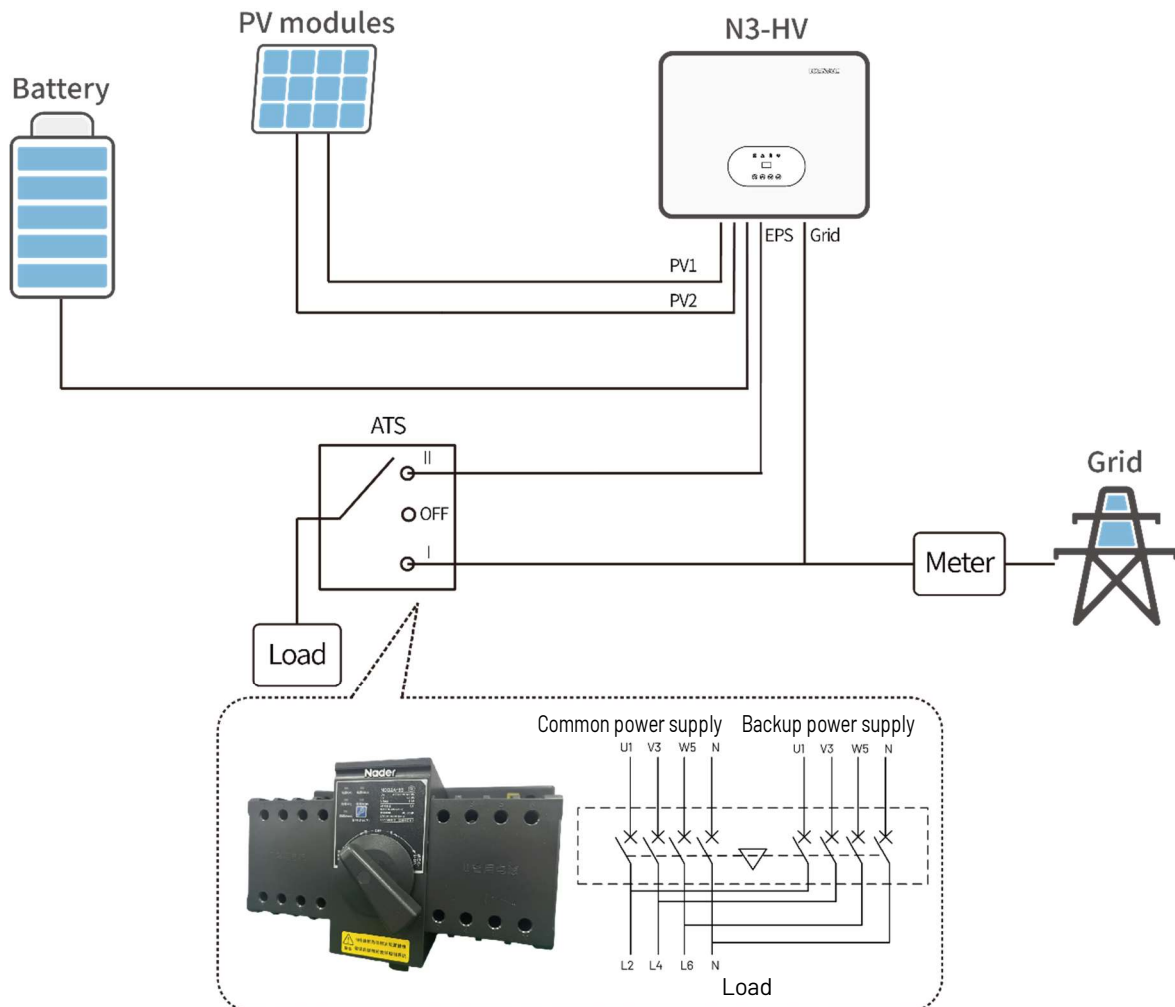

Figure 5-30 ATS connection wiring diagram

6. LED indicator status and operation button

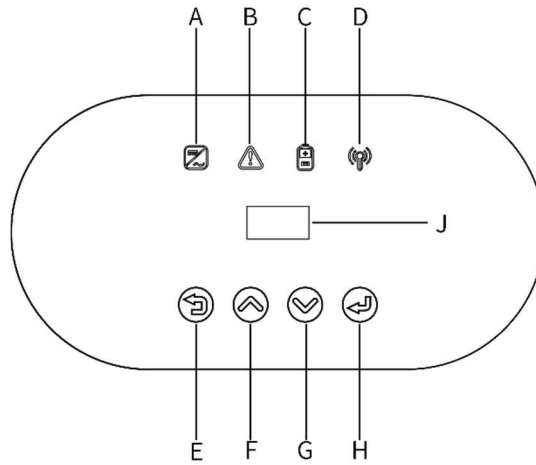

Figure 6-1

No.	Name	Description	
A	Green indicator	On	The inverter is in on-grid or off-grid operating state.
		Blinking	The inverter is in waiting, checking, or idle state.
		Off	This inverter has a communication fault.
B	Red indicator	On	The inverter has a fault.
		Blinking	The inverter has no fault, but the battery has a fault.
		Off	The inverter has no fault.
C	Blue indicator	On	Communication between the inverter and the battery is normal.
		Off	Communication between the inverter and the battery is abnormal.
D	Yellow indicator	On	Communication between the inverter and the monitoring dongle is normal.
		Blinking	Monitoring dongle failed to connect to the server.
		Off	Communication between the inverter and the monitoring dongle is abnormal.
E	Up button	Move cursor to upside or increase value.	
F	OK button	Press the button to confirm the selection.	
G	Down button	Move cursor to downside or decrease value.	
H	ESC button	Leave from current interface or function.	
J	LCD Screen	Display the information of the inverter.	

7. Commissioning

7.1 Check before powering on

Before powering on the N3-HV, please make sure that the product has been installed following the specifications, and carry out a comprehensive and detailed inspection of the system to ensure that all indicators are in line with the requirements before powering on the system.

(1) Installation check:

Installed correctly and securely.

(2) Electrical connection check:

The PE, DC input, AC output, and communication cables are connected correctly and securely.

(3) Switch check:

Ensure that the DC switches on the inverter and battery are off.

(3) Breaker check:

Ensure that all AC breakers are off.

(4) Other check:

Unused terminals and ports are locked by waterproof caps.

All the screws are tightened.

7.2 Power on

1. Turn on the external AC breaker of the grid side, and the green indicator of hybrid inverter is blinking.
2. Turn on the external EPS breaker.
3. Turn on the DC switch of the hybrid inverter.
4. Set the language, time, grid code, work mode, and meter setting on the screen of the hybrid inverter. Among them, meter 1 is enabled by default in the meter setting, and users only need to confirm that meter 1 is enabled. Then, turn on the system switch. (For details, please refer to Section 9.2.5).
5. Check the status of LED indicator and LCD screen. Firstly, the green indicator should be on and the LCD screen should display the main interface.



Please configure the inverter if operating first time.

Above steps are for regular start-up of the inverter. If the inverter is turned on for the first time, set the language, time, and safety regulations in turn according to the boot guidance.

If the green indicator is not on, please check the below:

- All the connections are right.
- All the external disconnect switches are turned on.
- The DC switch of the hybrid inverter is in the 'ON' position.

7.3 Power off

1. Turn off the system switch on the screen of the hybrid inverter. (For details, please refer to Section 9.2.5).
2. Turn off the external AC breaker of the grid side, and check the status of LED indicator and LCD screen. Firstly, the green indicator should be blinking and the LCD screen should be off.
3. Turn off the external EPS breaker.
4. Turn off the DC switch of the hybrid inverter, and the green indicator should be off.



Ensure that the DC cable is current-free using a Current Clamp meter.
 Even if the inverter is shut down, it may still be hot and cause burns. Wear protective gloves before working on the inverter.
 Wait about 10 minutes until the capacitors inside the inverter discharge completely.

8. Parallel system

8.1 System introduction

In order to continuously deliver power to large loads in both on-grid and off-grid situations, the N3-HV series supports parallel connection. Parallel connection is divided into parallel connection in on-grid mode, which supports ten units in parallel, and parallel connection in off-grid mode, which supports five units in parallel. In system with multiple inverters, one can connect the devices in a Master/Slave configuration. In this configuration, only one energy meter is connected to the Master inverter for the system control. Users should set up the master/slave on the screen or App after the inverter is connected.



The hybrid inverters in parallel mode need to be of the same type, and the batteries connected to the inverters need to be of the same type, too.

- In on-grid mode, the system connection is schematically shown below:

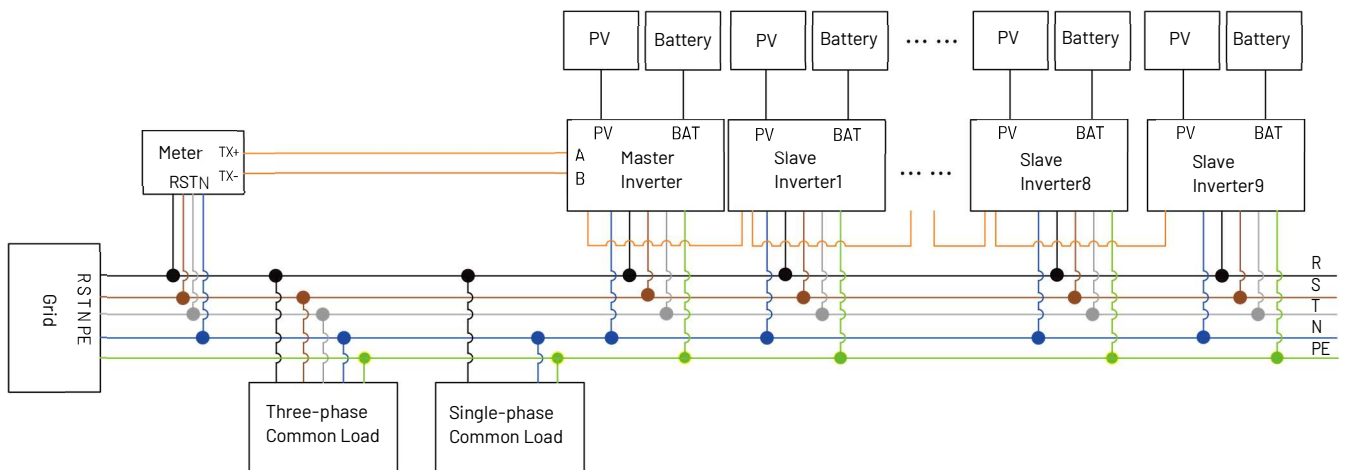

Figure 8-1 System Connection Diagram

In this mode, the length of the communication cable between the inverter and the inverter is not recommended to exceed 10m.

- In off-grid mode, the system should connect a large changeover device to achieve parallel functions in any conditions. We recommend the EPS parallel box from RENAC. There is a limitation on the speed of on-grid / off-grid switching. The system connection is schematically shown below:

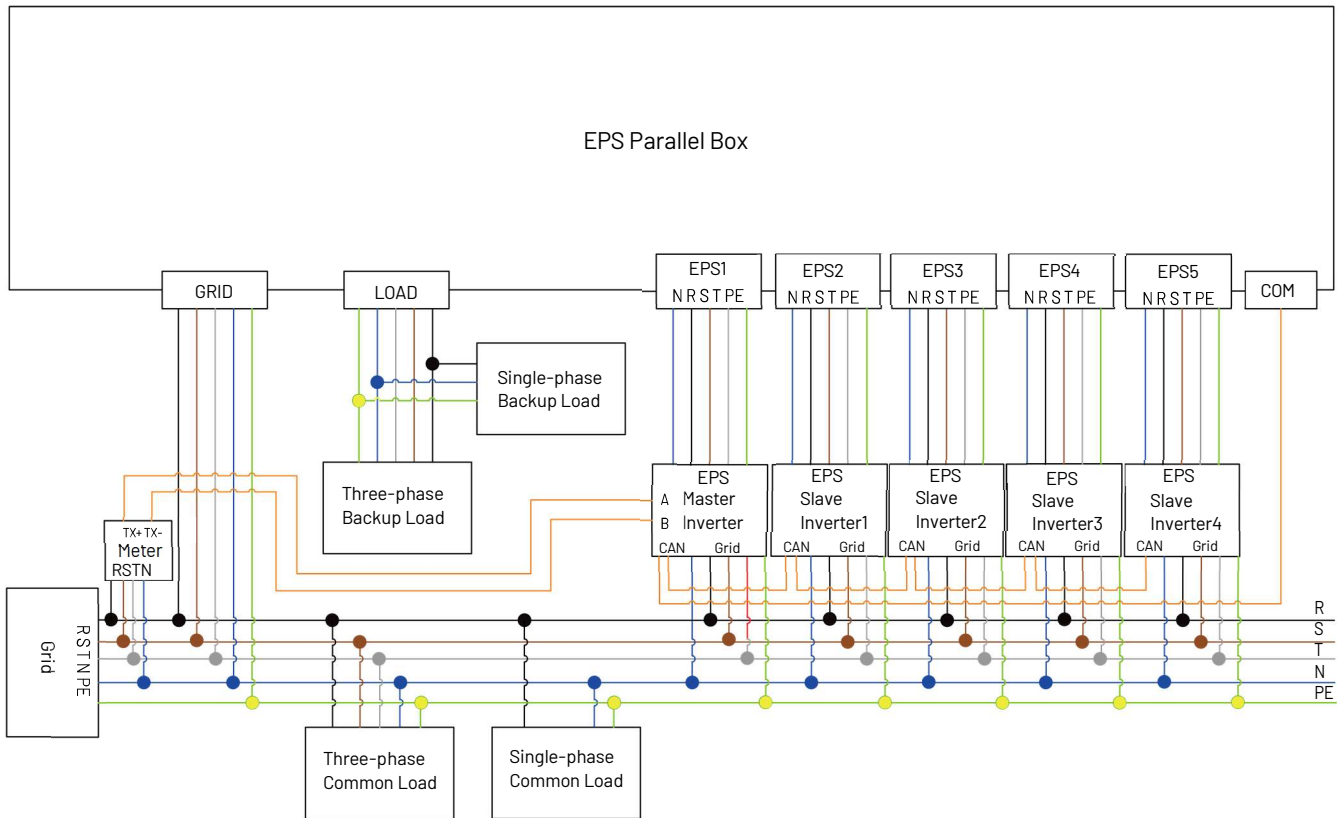

Figure 8-2 System Connection Diagram

In this mode, the length of the communication cable between the EPS Parallel Box and the Master inverter is not recommended to exceed 50m.

8.2 Work modes

There are three work modes in the parallel system, and your acknowledgment of different inverter’s work modes will help you understand the parallel system better.

- Single Mode: No one inverter is set as a "Master". All inverters are in single mode in the system.
- Master Mode: When one inverter is set as a "Master", this inverter enters master mode. The master mode can be changed to the single mode by LCD setting.
- Slave Mode: When one inverter is set as a "Master", all other inverters will enter slave mode automatically. Slave mode cannot be changed from other modes by LCD setting.

8.3 Communication connection

- The communication connection between Master Inverter and meter:
Connect the meter "TX+" "TX-" to inverter METER_485A and METER_485B referring to the Section 5.6.
- The communication connection between the Master Inverter and the parallel box:
Insert one side of the CAT7 cable into the first inverter's Parallel port and the other side into the COM port of the parallel box.
- The communication connection between Inverters:
Insert one side of the CAT7 cable into the first inverter's CAN port and the other side into the next inverter's CAN port.

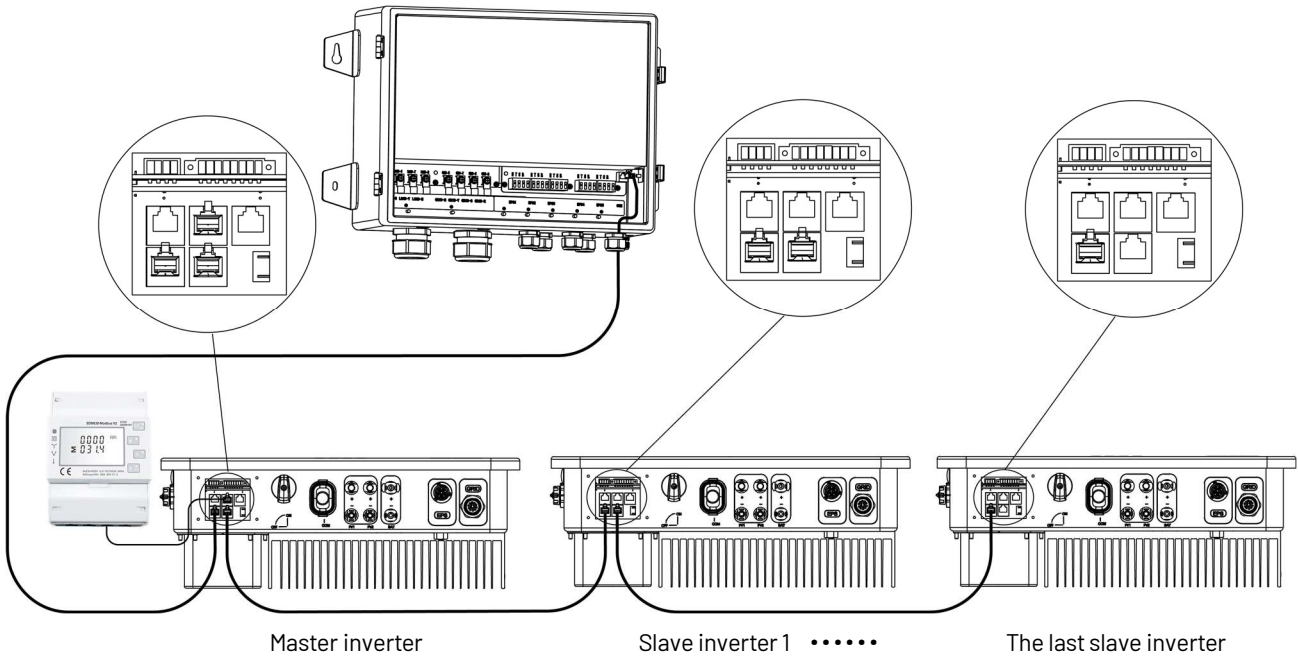

Figure 8-3

NOTICE

This schematic is an example of a parallel connection in off-grid mode, and the communication cable connection in on-grid mode is the same. But there's no EPS parallel box.

8.4 LCD setting

Users must turn the operation interface to "Advanced*". Press up or down button to set the parallel functional mode. Press OK button to confirm.

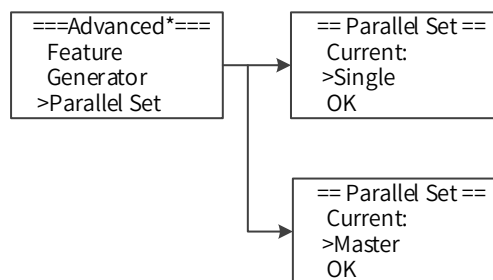

9. Operation and handling

9.1 Menu structure

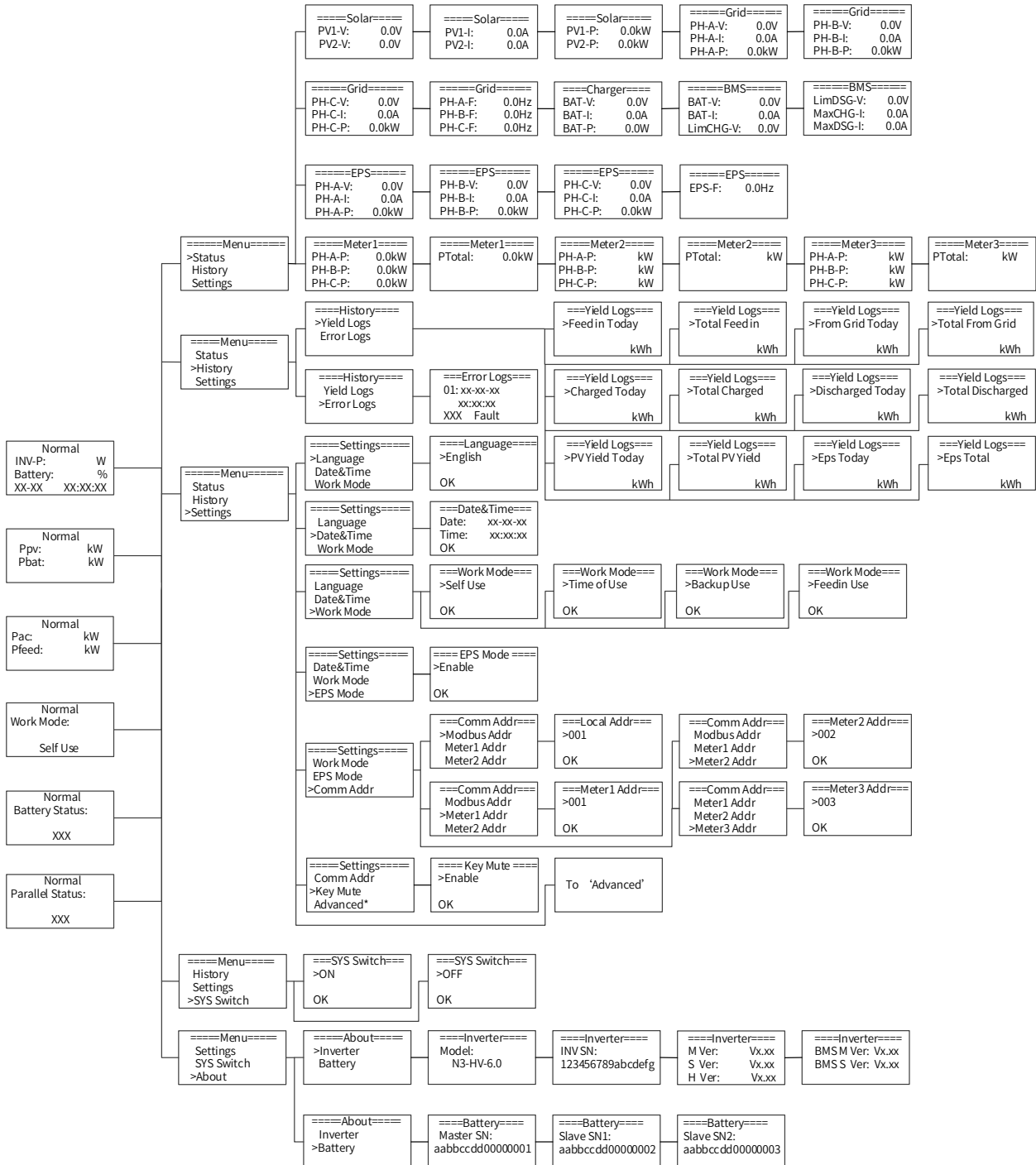

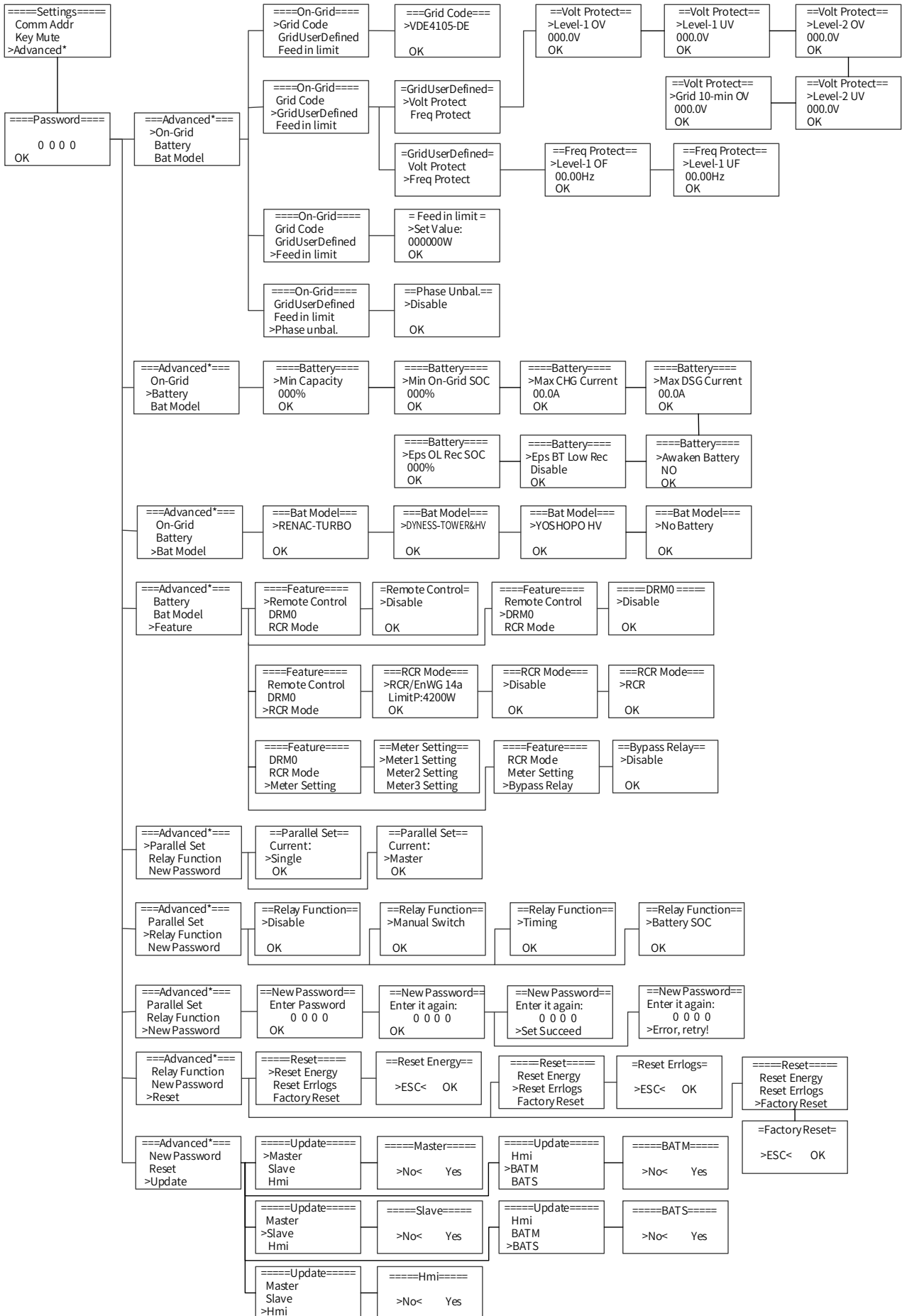

9.2 Operation

9.2.1 Main screen

The main screen as below. Press up or down for more information.

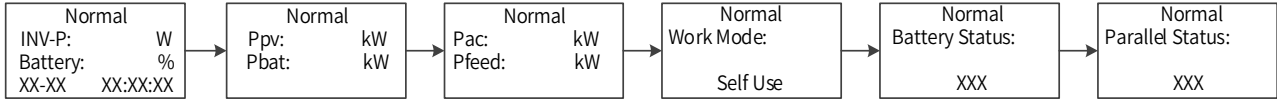

9.2.2 Status

Press the OK button to enter the status interface and check the real-time value of solar, grid, meter, charger, BMS, and EPS. Press up and down to select, and press the ESC button to return.

A) Solar

This status shows the real-time PV parameters of the system. The input voltage, current and power of each PV input. Press up and down button to review the parameter.

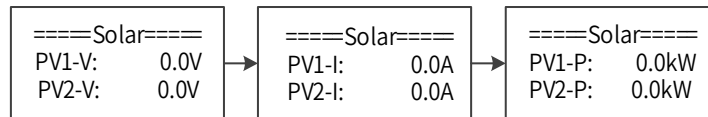

B) Grid

This status shows the real-time grid parameters such as voltage, current, output power and frequency. Press up and down button to review the parameter.

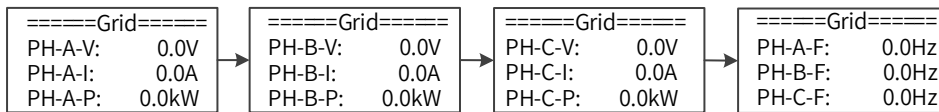

C) Meter

This status shows the meter situation of the system. Include the smart meter A, B, and C phase power and total power. Press up and down button to review the parameter. Press ESC button to return to Status.

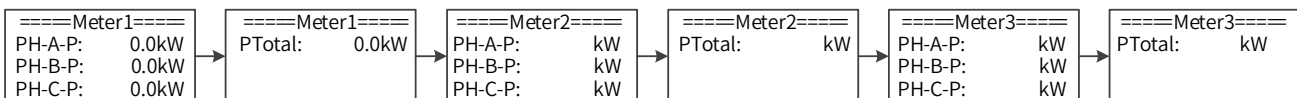

D) Charger

This status shows the charger situation of the system. Include the battery voltage, charge or discharge current. Charge or discharge power. '+' means in charging; '-' means in discharging. Press up and down button to review the parameter. Press ESC button to return to Status.

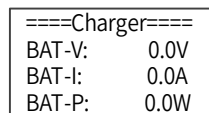

E) BMS

This status shows the battery situation of the system. Include the battery voltage and current, charge and discharge voltage, charge and discharge current. '+' means in charging; '-' means in discharging. Press up and down button to review the parameter. Press ESC button to return to Status.

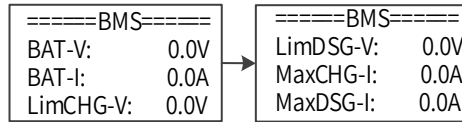

F) EPS

EPS will only have data when the inverter is working in EPS mode, it will show the real time data of the EPS output, as voltage, current, power, frequency. Press up and down button to review the parameter. Press ESC button to return to Status.

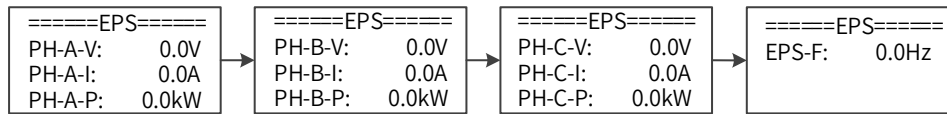

9.2.3 History

The history function contains three aspects of the information: inverter yield, battery yield and error log. Press up and down to select, and review the data of system, press ESC button to return to the Menu.

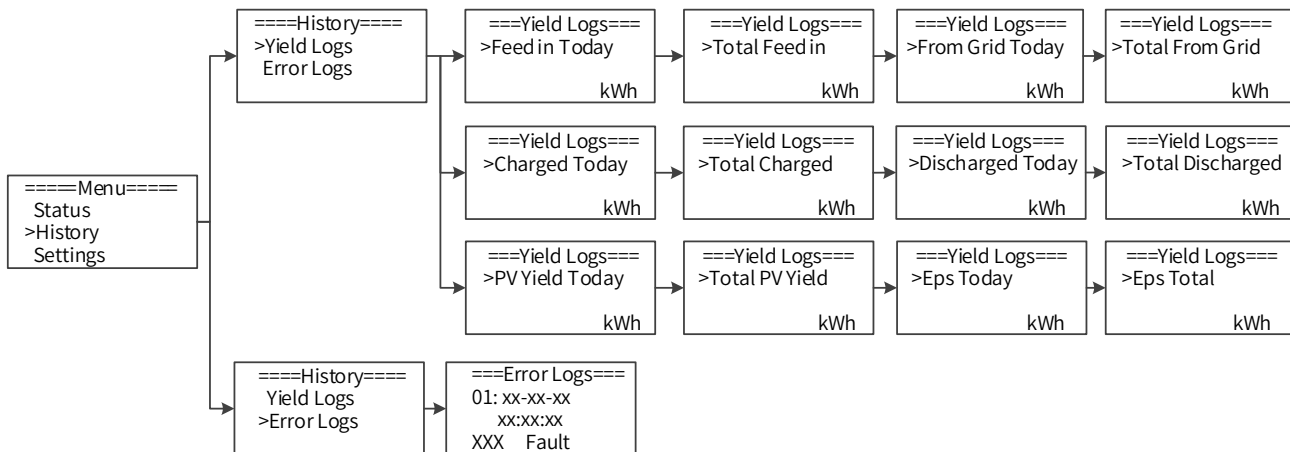

9.2.4 Settings

The setting function includes user settings and advanced* settings. The user settings include language, date & time, work mode, EPS mode, communication address, and key mute. The advanced* settings include on-grid, battery, bat model, feature, parallel set, relay function, new password, reset, and update.

In the setting function, press the OK button to enter the second confirmation interface; users need to select OK button to confirm formally. If the setting is successful, 'Set Succeed' will be displayed below, and the page will automatically return to the previous page in a while; if the setting fails, 'Set Failed' will be displayed below, and the page will be fixed, and the user will need to press the Back button to return to the previous page. Take setting the language as an example.

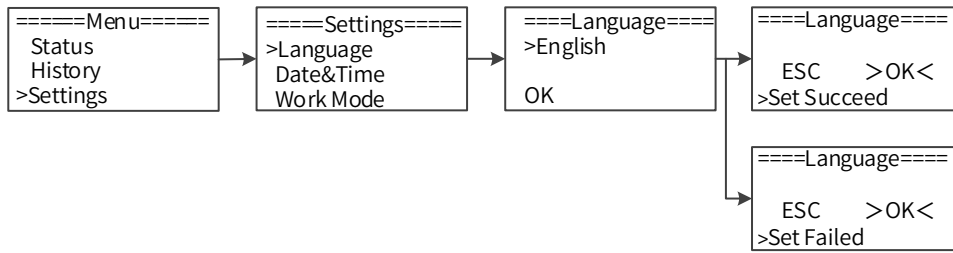

A) Language

Press up or down button to change language. Press OK button to confirm.

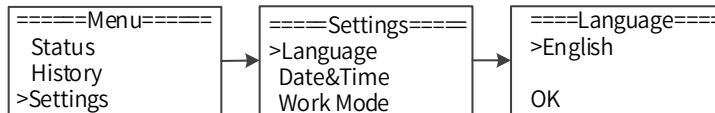

B) Date Time

Press up or down button to change date and time. Press OK button to confirm.

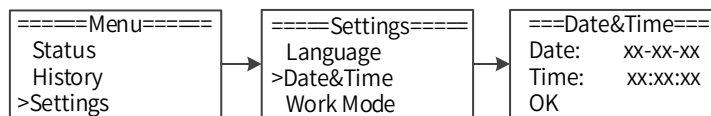

C) Work Mode

Press up or down button to select different work modes. Press OK button to confirm.

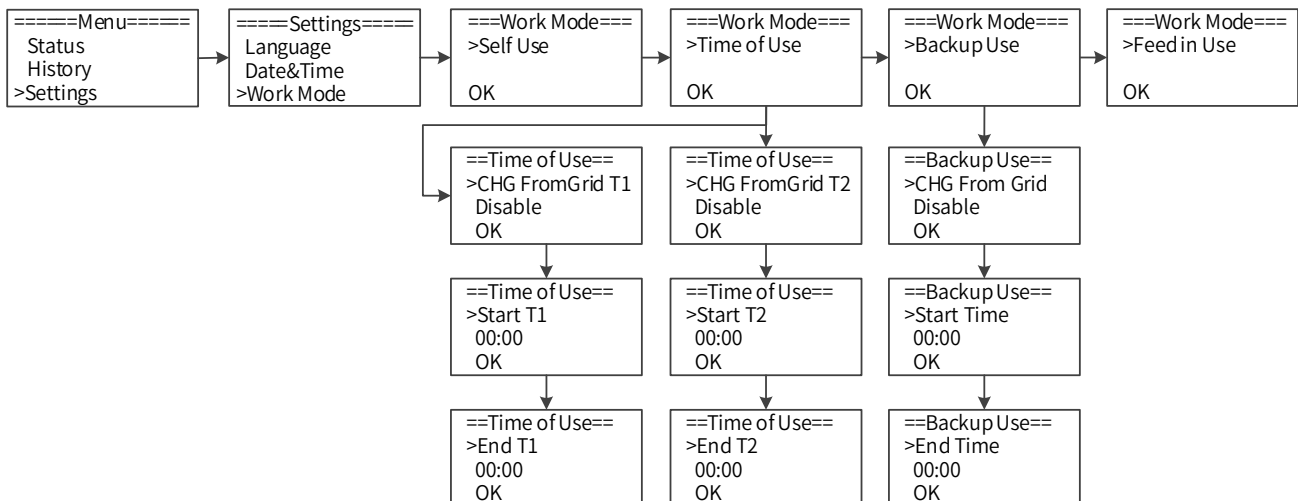

D) EPS mode

Press up or down button to change the EPS Mode enable state. The default EPS Mode is enable. If this function is disabled, the hybrid inverter will not automatically switch to EPS mode in the off-grid state.

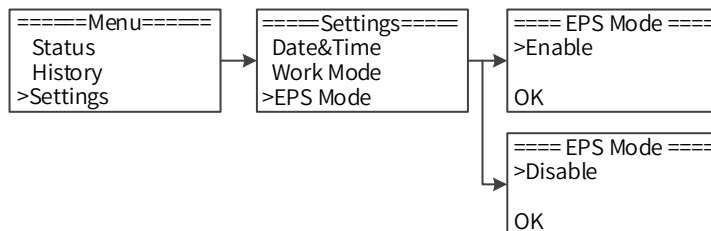

E) Communication Address

Press up or down button to change address of local and meter. Press OK button to confirm.

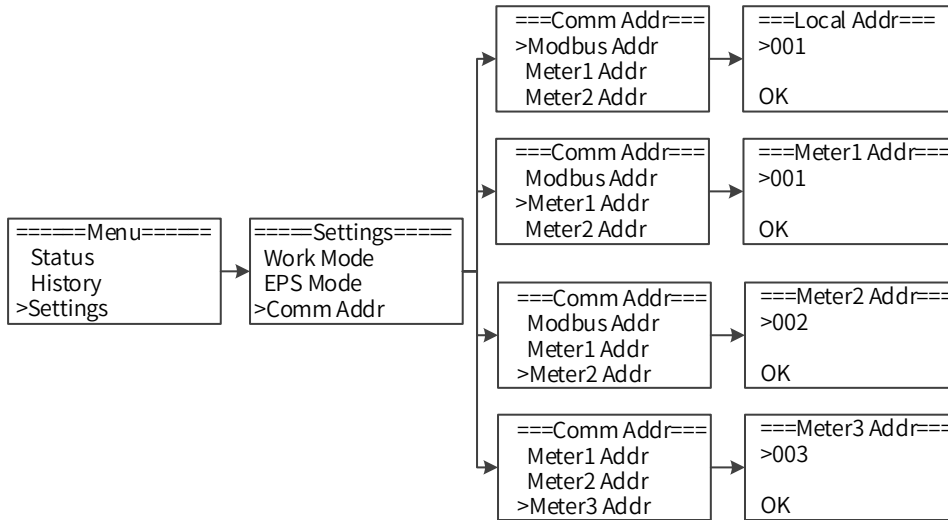

F) Key mute

Press the up or down button to select whether to enable the key mute. Press the OK button to confirm.

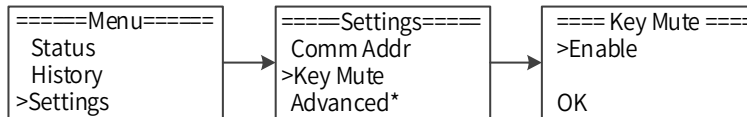

G) On-grid

First of all, if the user wants to enter the Advanced* setting interface, verify the user identity and enter the default password '0000' to enter the setting interface.

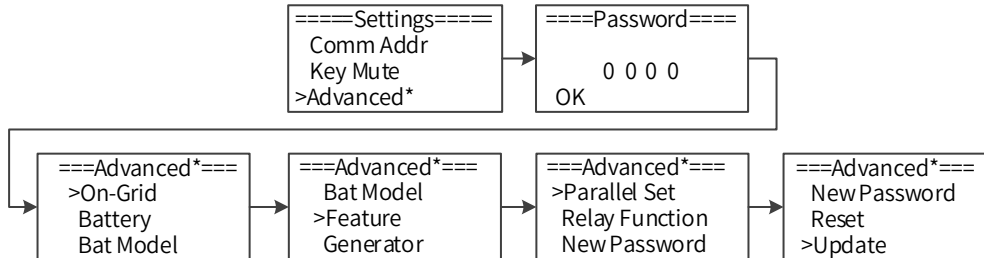

The on-grid function includes Grid Code, Grid User Defined, Feed in limit and Phase unbalance.

(1) Grid Code: Press the up or down button to set the grid code. Press the OK button to confirm.

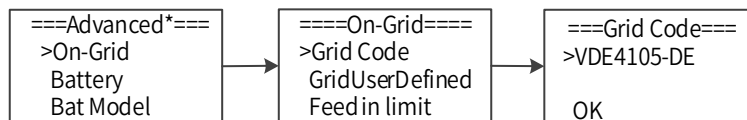

For compliance with AS/NZS 4777.2:2020, please select from Australia A/B/C/ or New Zealand.
Please contact your local grid operator to select the region according to the grid code list.

Grid codes:

No.	National/Regional Grid Code	Description
0	VDE4105-DE	Germany power Grid, meet Grid standards "VDE-AR-N-4105".
1	CEI0-21	Italy power Grid.
2	Australia A	Australia A power Grid.
3	RD1699	Spain power Grid.
4	EN50549	Default EN50549 Grid setting.
5	EN50549-DK-W	West Denmark power Grid.
6	Greece	Greece power Grid.
7	EN50549-NL	Netherland power Grid.
8	C10/11	Belgium power Grid.
9	G99	UK power Grid.
10	China	China power Grid, meet Grid standards "CN-NBT".
11	VDE0126-FR	France power Grid, meet Grid standards "VDE 0126".
12	EN50549-PL	Poland power Grid.
13	Brazil-180s	Brazil power Grid, connect/reconnect time 180s.
14	VDE0126-DE	Germany power Grid, meet Grid standards "VDE 0126".
15	CEI0-16	Italy power Grid, meet Grid standards "CEI0-16".
16	G98	UK power Grid.
17	Greece Island	Greece Island power Grid.
18	EN50549-CZ	Czech Republic power Grid.
19	IEC61727-IN	India power Grid.
20	Korea	Korea power Grid.
21	EN50549-SW	Sweden power Grid.
22	China-W	China power Grid, Grid voltage range: 160-264.5V. Grid frequency range: 47-52Hz.
23	China-H	China power Grid. Grid voltage range: 160-280V.
24	IEC61727-IN-W	India power Grid. Grid voltage range: 195.5-280V.
25	Brazil	Brazil power Grid, meet Grid standards "NBT 16150".
26	IEC61727-SL	Sri Lanka power Grid, meet Grid standards "IEC61727".
27	Mexico	Mexico power Grid, meet Grid standards "IEC61727 60Hz".
28	New Zealand	New Zealand power Grid.
29	Philippines	Philippines power Grid, meet Grid standards "IEC61727 60Hz".
30	IEC61727-SL-W	Sri Lanka power Grid, Grid voltage range: 160-280V. Grid frequency range: 47-52Hz.
31	PEA	Thailand power Grid.
32	PEA-W	Thailand power Grid. Grid voltage range: 160-280V. Grid frequency range: 47-52Hz.
33	IEC61627-VN	Vietnam power Grid.
34	IEC61627-VN-W	Vietnam power Grid. Grid voltage range: 160-280V. Grid frequency range: 47-52Hz.
35	Tunisia	Tunisia.

No.	National/Regional Grid Code	Description
36	MEA	Thailand power Grid.
37	MEA-W	Thailand power Grid. Grid voltage range: 160-280V. Grid frequency range: 47-52Hz.
38	Brazil-LV	120V 60Hz voltage of grid L to N (R3-10-15K-LV only, others reserved).
39	EN50549-DK-E	East Denmark power Grid.
40	Tunisia-W	Tunisia wide range. Grid voltage range: 160-290V.
41	Chile	Chile Power Grid.
42	Brazil-W	Brazil power Grid. Grid voltage range: 160-290V.
43	EN50549-PL-W	Poland power Grid. Grid voltage range: 160-290V.
44	Brazil-180s-W	Brazil power Grid. Grid voltage range: 160-290V.
45	UNE217002-ES	Spain power Grid.
46	G98-NI	G98 for Northern Ireland.
47	G99-NI	G99 for Northern Ireland.
48	EN50549-NW	Norway-400VLine
49	EN50549-NW-LV	Norway-230VLine-R3-10-15K-LV only, others reserved.
50	IEC61727-LV	133V 50Hz, low voltage power grid.
51	EN50549-IR*/	Ireland power Grid.
52	Austria	Austria power Grid.
53	Australia B	Australia B power Grid.
54	Australia C	Australia C power Grid.
55	EN50549-SIST	Slovenia Grid.
56	EN50549-HUN	Hungary Grid.
57	Pakistan	Pakistan Grid.

(2) Grid User Defined: Press the up or down button to change the value of grid voltage and grid frequency protect. Press the OK button to confirm.

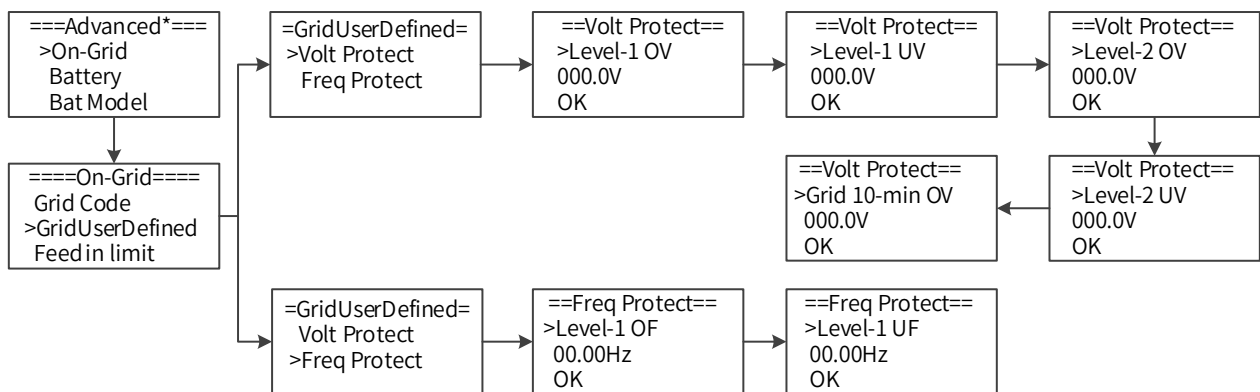

(3) Feed in limit: With this function the inverter can control the power export to the grid. Press the up or down button to change the export power. Press the OK button to confirm.

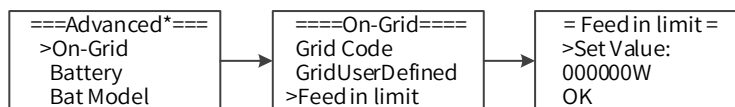

(4) Phase unbalance: When the system is connected with three-phase unbalanced load or single-phase load, customers can enable the phase unbalance function, the inverter can detect and identify the three-phase current unbalance in the system through the meter and output unbalanced power to different phase.

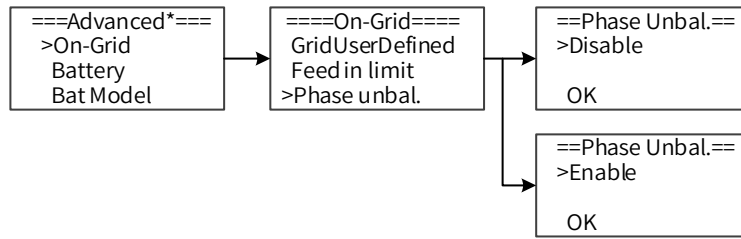

H) Battery

Press up or down button to set the parameters of battery. 'Eps BT Low Rec' means recovery enable switch when battery low capacity in EPS mode. 'Eps OL Re SOC' means EPS overload due to low capacity for battery, if recovered, min soc. Press OK button to confirm. Users need to set the battery model before using, press OK button to confirm.

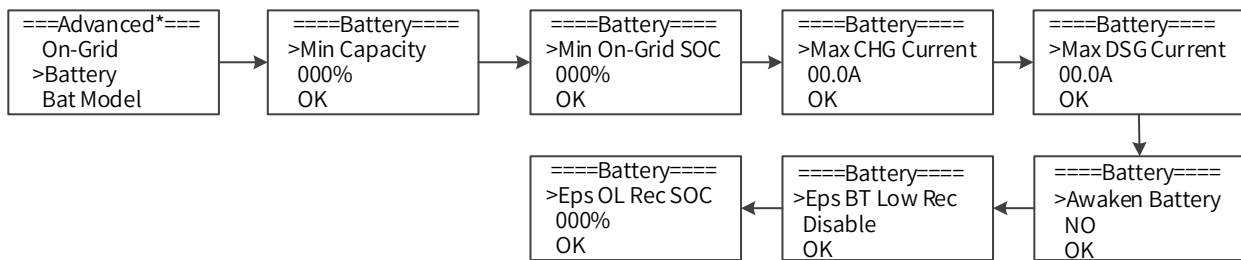

I) Bat Model

Press up or down button to set the model of battery. Press the OK button to confirm. If the battery is not connected, select 'No Battery'.

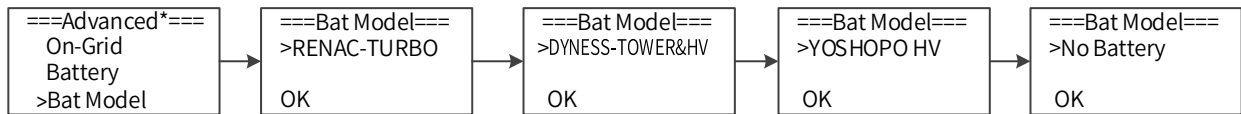

J) Feature

Press up or down button to enable or disable Remote Control, DRM0, RCR, and Meter Setting. Press OK button to confirm.

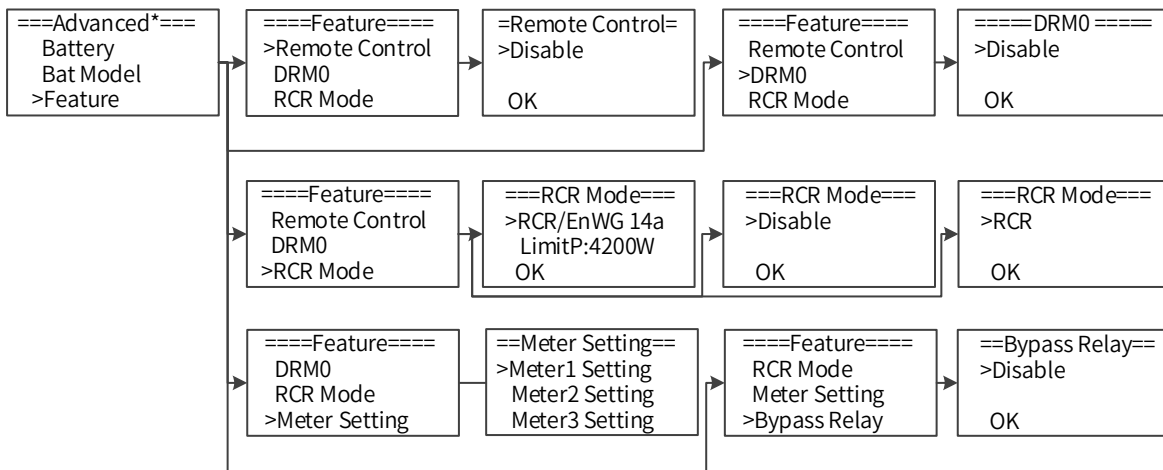

K) Parallel set

Press up or down button to set the inverter is in single mode or parallel mode. Please refer to Section 8 for details.

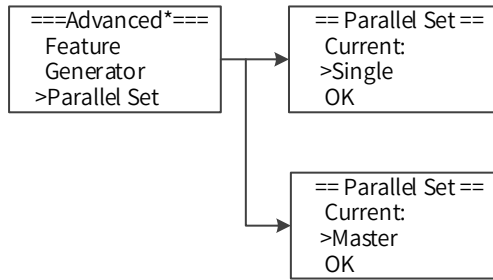

L) Relay Function

Press up or down button to set the relay function. Press OK button to confirm.

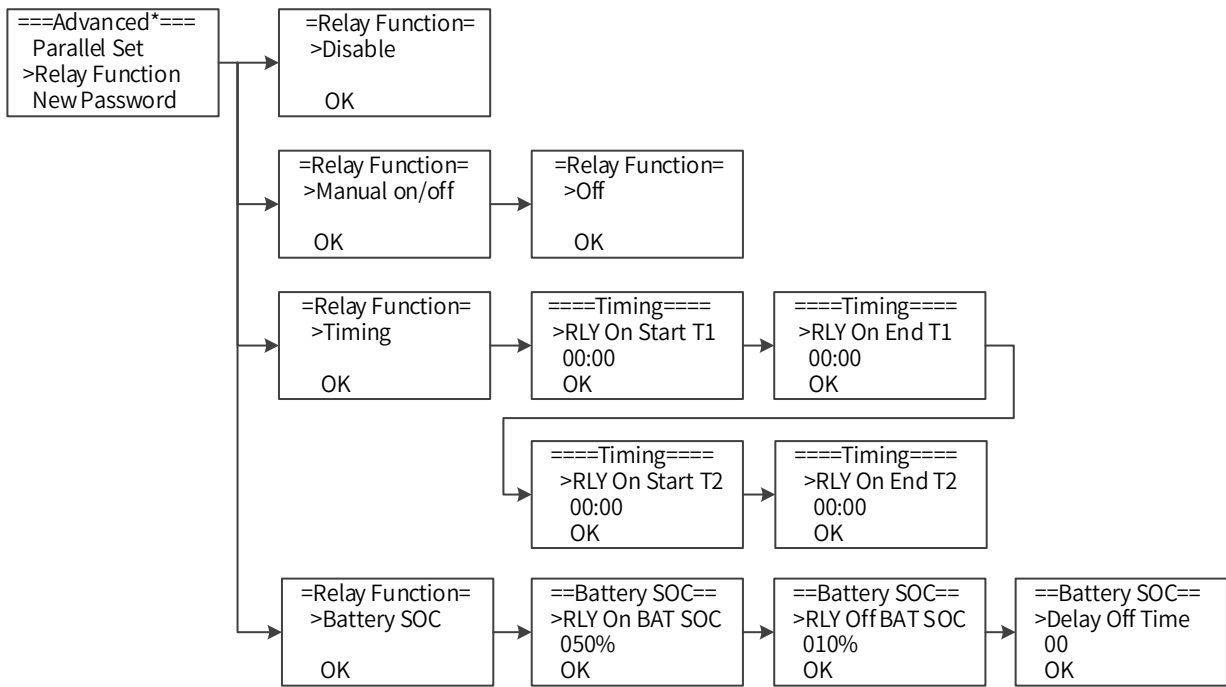

M) New Password

Press up or down button to set new password. Press OK button to confirm.

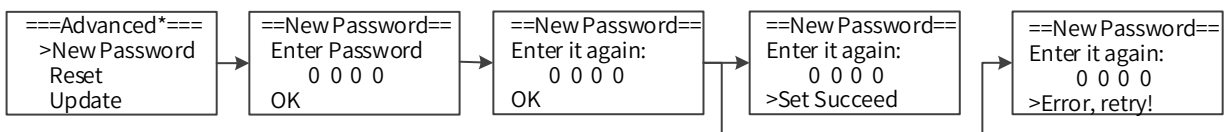

N) Reset

Press up or down button to reset energy, reset errors or factory reset. Press OK button to confirm.

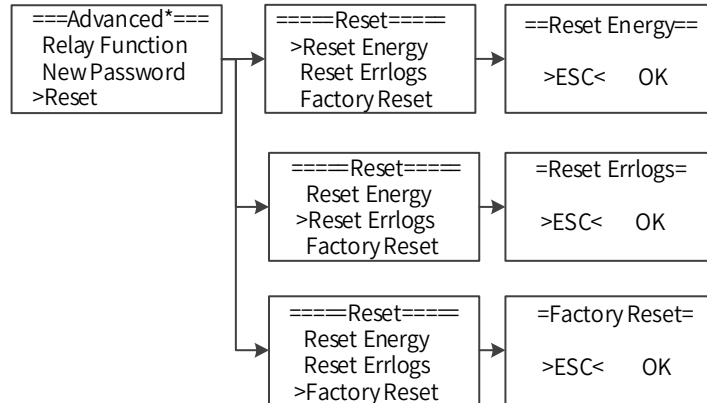

O) Update

Press up or down button to upgrade DSPM, DSPS, ARMC, BATM or BATS. Press OK button to confirm.

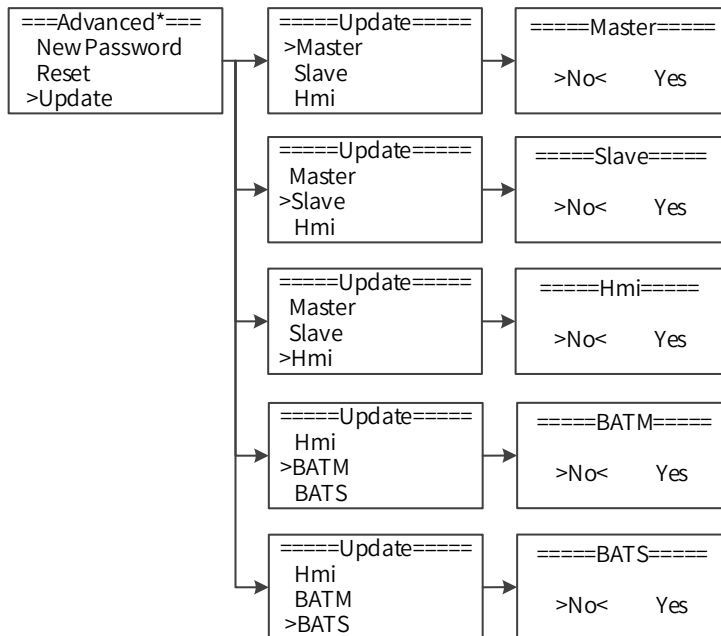

9.2.5 System Switch

Press up or down button to turn on or turn off the inverter. Press OK button to confirm.

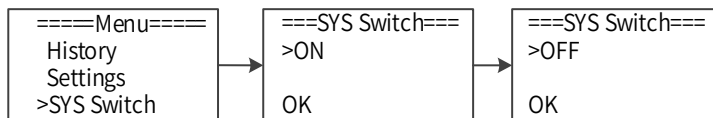

9.2.6 About

This interface shows the information of the inverter, such as series number and software version.

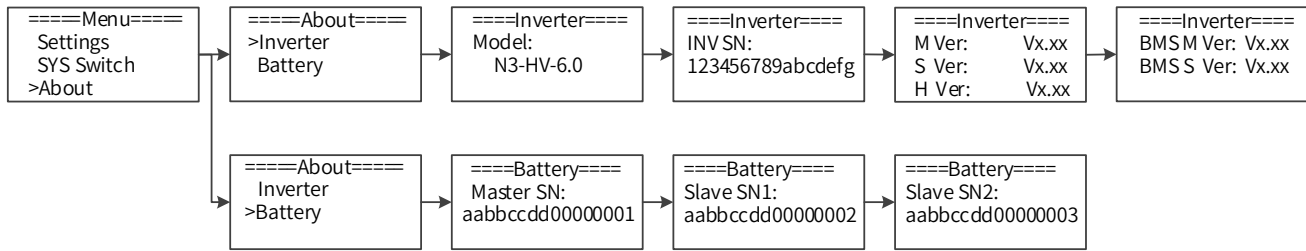

9.2.7 Self-Test in accordance with CEI 0-21 (Applies to Italy only)

The self-test is only required for inverters, which are commissioned in Italy. The Italian standard requires that all inverters feeding into the utility grid are equipped with a self-test function in accordance with CEI0-21. Please note that there is a self-test option only when the inverter selects CEI 0-21. During the self-test, the inverter will consecutively check the protection reaction times and values for overvoltage, under voltage, over frequency and under frequency Self-test function is available at any time. It also allows end user get test reports shown on LCD display.

Note: Users need to set the inverter country to CEI 0-21 before testing.

Auto-Test from screen:

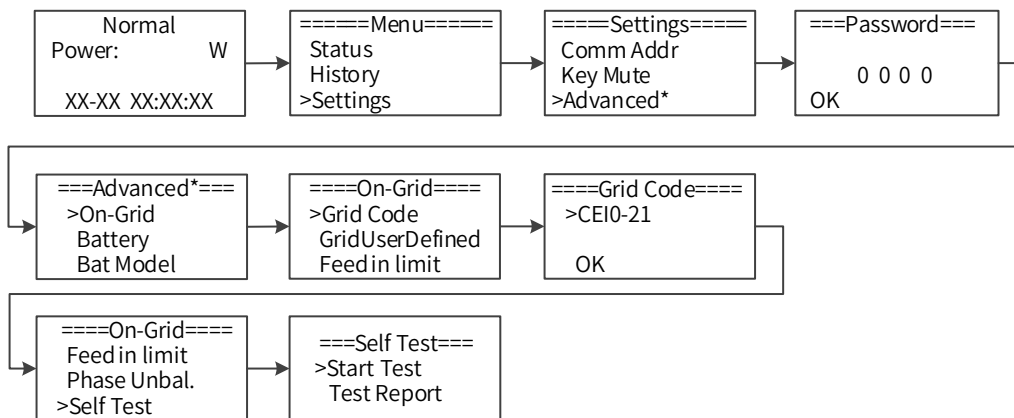

10. Troubleshooting

This section contains information and procedures for solving possible problems with the N3-HV series inverters, and provides you with troubleshooting tips to identify and solve most problems that could occur with the N3-HV series inverters.

This section will help you narrow down the source of any problems you may encounter. Please read the following troubleshooting steps.

- Check the warning or fault messages on the System Control Panel or Fault codes on the inverter information panel. If a message is displayed, record it before doing anything further.
- Attempt the solution indicated in below table.

Fault	Cause	Solutions
HW Protect	Inverter over-current, battery over-current, or PV over-current detected by hardware.	1. Disconnect the AC output switch, DC input switch & battery switch, then connect them 5 minutes later. 2. Contact the dealer or the after-sales service if the problem persists.
Grid Failure	1. Utility grid power fails. 2. The AC cable is disconnected, or the AC breaker is off.	1. The alarm is automatically cleared after the grid power supply is restored. 2. Check whether the AC cable is connected and the AC breaker is on.
Grid Volt Fault	1. The grid voltage exceeds the permissible range, or the duration of high voltage exceeds the requirement of HVRT. 2. The grid voltage is lower than the permissible range, or the duration of low voltage exceeds the requirement of LVRT.	1. If the problem occurs occasionally, the utility grid may be abnormal temporarily. The inverter will recover automatically after detecting that the utility grid is normal. 2. If the problem occurs frequently, check whether the grid voltage is within the permissible range.
Grid Freq Fault	1. Utility grid exception. The actual grid frequency exceeds the requirement of the local grid standard. 2. Utility grid exception. The actual grid frequency is lower than the requirement of the local grid standard.	1. If the problem occurs occasionally, the utility grid may be abnormal temporarily. The inverter will recover automatically after detecting that the utility grid is normal. 2. If the problem occurs frequently, check whether the grid frequency is within the permissible range.
PV-V Fault	PV voltage out of range.	Check the serial connection of the PV module. Make sure that the open circuit voltage of the PV module is not higher than the maximum operating voltage of the inverter.
Bus Volt Fault	Bus voltage out of range detected by hardware.	1. Disconnect the AC output switch, DC input switch & battery switch, then connect them 5 minutes later. 2. Contact the dealer or the after-sales service if the problem persists.
Bat Volt Fault	Battery voltage fault.	Check if the battery input voltage is within the normal range, then restart the system and confirm whether the fault persists.

Fault	Cause	Solutions
Grid 10-min OV	The grid voltage is out of range for the last 10 Minutes.	<ol style="list-style-type: none"> 1. If the problem occurs occasionally, the utility grid may be abnormal temporarily. The inverter will recover automatically after detecting that the utility grid is normal. 2. If the problem occurs frequently, check whether the grid voltage is within the allowed range. <ul style="list-style-type: none"> • Contact the local power company if the grid voltage exceeds the permissible range. • Modify the grid overvoltage rapid protection threshold after obtaining the consent of the local power company if the grid voltage is within the permissible range.
DCI OCP	DC component is out of limit in output current.	<ol style="list-style-type: none"> 1. Disconnect the AC output switch, DC input switch & battery switch, then connect them 5 minutes later. 2. Contact the dealer or the after-sales service if the problem persists.
DCV OVP	DC component is out of limit in output voltage.	
SW OCP	Output current high detected by software.	
RC OCP	The residual current is high.	<ol style="list-style-type: none"> 1. If the problem occurs occasionally, it may be caused by a cable exception. The inverter will recover automatically after the problem is solved. 2. Check whether the impedance between the PV module and PE is too low if the problem occurs frequently or persists.
Iso Check Fault	<ol style="list-style-type: none"> 1. The PV module is short-circuited to PE. 2. The PV system is in a moist environment and the cable is not well insulated to the ground. 	<ol style="list-style-type: none"> 1. Check whether the resistance of the PV module to PE exceeds 50kΩ. If no, check the short circuit point. 2. Check whether the PE cable is connected correctly.
Over TEMP Fault	The inverter temperature is high.	Check the ventilation and the ambient temperature at the installation point. If the ventilation is poor or the ambient temperature is too high, improve the ventilation and heat dissipation.
BatConDir Fault	The battery connection is reversed.	<ol style="list-style-type: none"> 1. Check if the positive pole and negative pole of battery are correctly connected. 2. Contact the dealer or the after-sales service if the problem persists.
Sample Fault	The sampling value between the main and slave DSP is inconsistent.	<ol style="list-style-type: none"> 1. Disconnect the AC output switch, DC input switch & battery switch, then connect them 5 minutes later. 2. Contact the dealer or the after-sales service if the problem persists.
EPS Over Load	EPS over load.	<ol style="list-style-type: none"> 1. Check the EPS load to ensure it does not exceed the inverter EPS Rated Power. 2. Disconnect the AC output switch and DC input switch & battery switch, then connect them 5 minutes later.

Fault	Cause	Solutions
EPS OCP	EPS over current.	<ol style="list-style-type: none"> 1. Check the EPS load to ensure it does not exceed the inverter EPS Rated current. 2. Disconnect the AC output switch and DC input switch & battery switch, then connect them 5 minutes later.
PLL Error	PLL Error.	<ol style="list-style-type: none"> 1. Disconnect the AC output switch, DC input switch & battery switch, then connect them 5 minutes later. 2. Contact the dealer or the after-sales service if the problem persists.
Parallel Fault	Inverter parallel connection fault.	<ol style="list-style-type: none"> 1. Check if the parallel wiring is correct. 2. Check the inverter setting, ensure that only one inverter was set to "Master".
Bat Low Fault	Battery SOC is too Low.	<ol style="list-style-type: none"> 1. Wait the battery to be recharged. 2. Disconnect the AC output switch and DC input switch, then connect them 5 minutes later. Contact the dealer or the after-sales service if the problem persists.
Ground Fault	Inverter grounding issue.	<ol style="list-style-type: none"> 1. Check whether the PE cable of the inverter is connected properly. 2. Check whether the L cable and N cable are connected reversely if output of the PV module is grounded.
BMS COM Fault	The communication between BMS and Inverter is interrupted.	Check if the communication cable between BMS and inverter is connected correctly.
Other Dev Fault	Other device fault.	<ol style="list-style-type: none"> 1. Disconnect the AC output switch, DC input switch & battery switch, then connect them 5 minutes later. 2. Contact the dealer or the after-sales service if the problem persists.
M/S COM Fault	The communication between master and slave is fault.	
Fan Fault	Internal fan Device failure.	
HCT Fault	AD sampling failure.	
Inv EEPROM Fault	DSP EEPROM failure.	
RCD Fault	Leakage current detection circuit fault.	
EPS Relay Fault	<ol style="list-style-type: none"> 1. The relay is abnormal or short-circuited. 2. The control circuit is abnormal. 3. The AC cable connection is abnormal, like a virtual connection or short circuit. 	<ol style="list-style-type: none"> 1. Disconnect the AC output switch, DC input switch & battery switch, then connect them 5 minutes later. 2. Contact the dealer or the after-sales service if the problem persists.
Grid Relay Fault		
Bypas Relay Fault		
HMI EEPROM Fault	HMI eeprom failure.	<ol style="list-style-type: none"> 1. Disconnect the AC output switch, DC input switch & battery switch, then connect them 5 minutes later. 2. Contact the dealer or the after-sales service if the problem persists.
Meter1 COM Fault	The communication between smart meter1 and Inverter is interrupted.	1. Check if the communication cable between smart meter and Inverter is connected correctly.

Fault	Cause	Solutions
Meter2 COM Fault	The communication between smart meter2 and Inverter is interrupted.	2. Check if the smart meter is powered on.
Meter3 COM Fault	The communication between smart meter3 and Inverter is interrupted.	
H/M COM Fault	The communication is fail between ARM and master DSP.	1. Disconnect the AC output switch, DC input switch & battery switch, then connect them 5 minutes later. 2. Contact the dealer or the after-sales service if the problem persists.
BMS AD_AFE Fault	The difference between the total voltage of battery AD and AFE is too large.	1. Disconnect the AC output switch, DC input switch & battery switch, then connect them 5 minutes later. 2. Contact the dealer or the after-sales service if the problem persists.
BMS TEMP Fault	Battery temperature sensor fault.	
BMS InCom Fault	Battery internal communication fault.	Disconnect battery, check wiring between inverter and battery, battery internal wiring then reconnect.
BMS PreChg Fault	Battery pre charge fault.	1. Disconnect the AC output switch, DC input switch & battery switch, then connect them 5 minutes later. 2. Contact the dealer or the after-sales service if the problem persists.
BMS Relay Fault	The battery relay is fault.	
BMS Cell Fault	Battery cell error.	
BMS Other Fault	Other battery fault.	
BMS OV	Battery over voltage protection.	
BMS UV	Battery under voltage protection.	
BMS Charge OC	Battery over current charging protection.	
BMS Discharge OC	Battery over current discharging protection.	1. Disconnect the AC output switch, DC input switch & battery switch, then connect them 5 minutes later. 2. Contact the dealer or the after-sales service if the problem persists.
BMS TEMP High	Battery temperature is high.	
BMS TEMP Low	Battery temperature is low.	
BMS Volt Fault	Battery voltage sensor fault.	
BMS OutCom Fault	BMS external communication fault.	
BMS ISO Fault	Battery insulation test failed.	
BMS Check Fault	Battery self-test failed.	
BMS Prot TemDiff	The difference in battery cell temperature is too large.	
BMS Prot AD_AFE	The difference between the total voltage of battery AD and AFE is too large, triggering protection.	
BMS Prot Hard OC	Battery hardware overcurrent protection.	

Remark

If you find the inverter has serious problems, including but not limited to the above content, please call Renac dealer or the after-sales service. Please provide the following information to www.renacpower.com for better service.

- (1) Customer Name
- (2) Contact Info
- (3) Project Name and Location
- (4) Project Scale
- (5) Quantity of Faulty Inverters
- (6) Problem Description
- (7) Inverter Model
- (8) Inverter SN

11. Decommissioning

11.1 Dismantling

- Disconnect the inverter from DC input and AC output.
- Disconnect battery wiring.
- Wait for 5 minutes for de-energizing.
- Disconnect communication and optional connection wiring.
- Remove the inverter from the bracket.

11.2 Packing

If possible, please pack the inverter in the original packaging.

If it is no longer available, you can also use an equivalent carton that meets the following requirements.

- Suitable for loads more than 27kg.
- With handle.
- Can be fully closed.

11.3 Storage

Store the inverter in dry place where ambient temperatures are always between -20°C - $+60^{\circ}\text{C}$.

11.4 Disposal

When the N3-HV or other related components need to be disposed of, have it carried out according to local waste handling regulations. Please be sure to deliver wasted inverters and packing materials to a certain site where the relevant department can dispose of and recycle them.

12. Appendix A

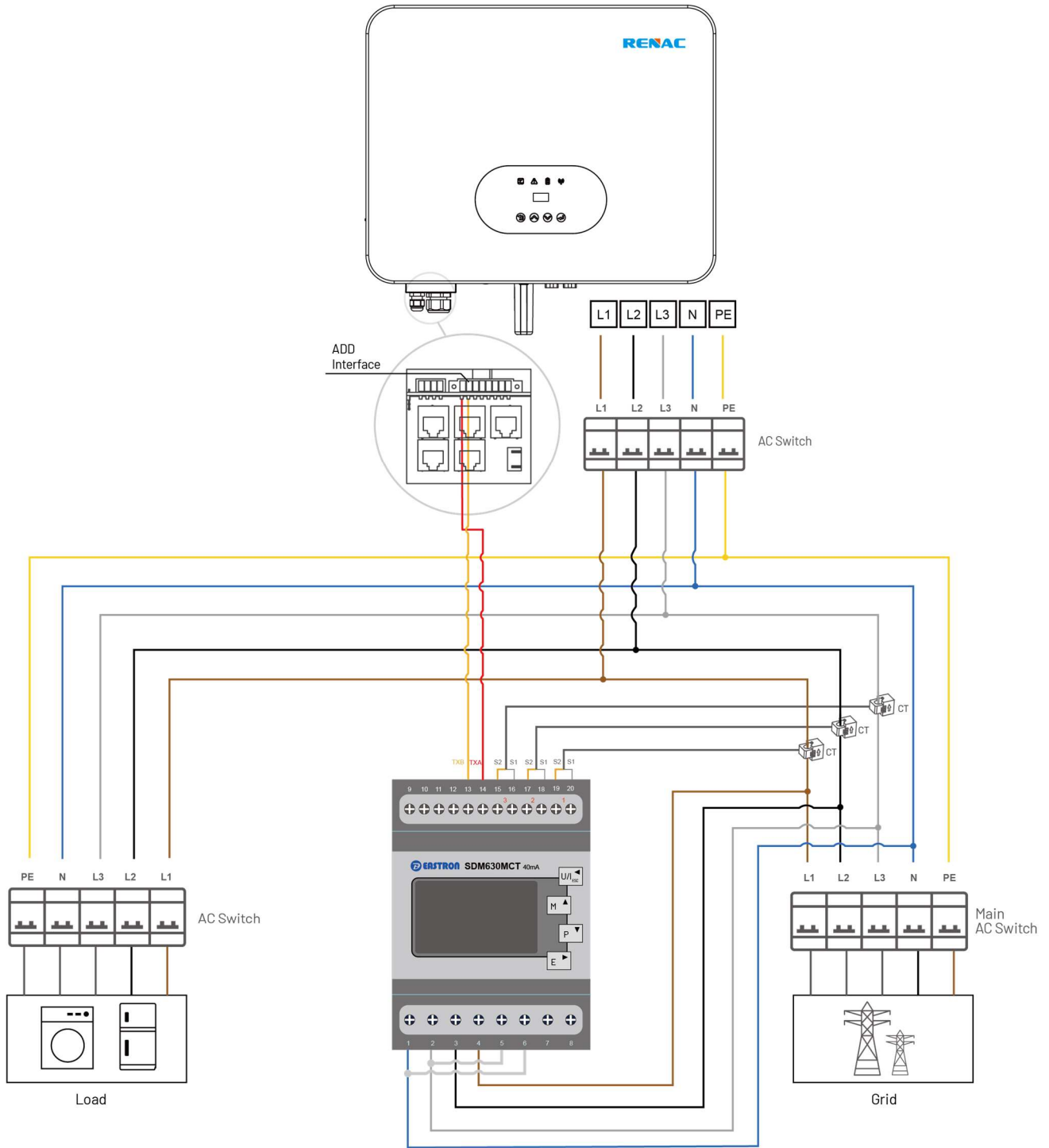

13. Appendix B

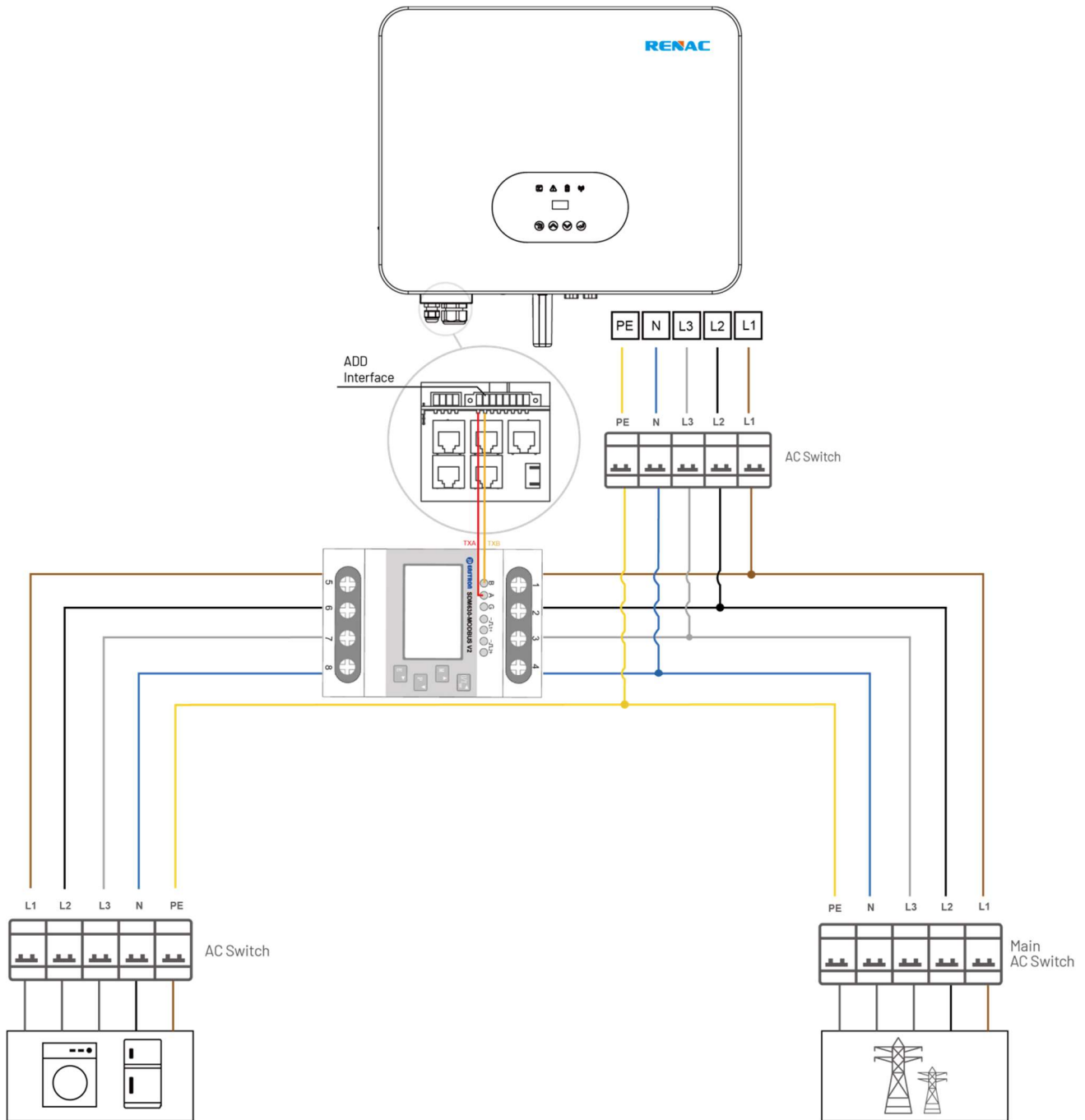



User Manual Download URL



www.renacpower.com

422-00014-08

SMART ENERGY FOR BETTER LIFE

RENAC

RENAC POWER TECHNOLOGY CO., LTD.

📞 +86-0512-66677278

✉ info@renacpower.com

🌐 www.renacpower.com

🏠 Block C-12, No. 20 Datong Road, Comprehensive Bonded Zone,
Suzhou Hi-Tech District, Suzhou, China