

CE

Teläir

AIR CONDITIONER



Silent 7300H

MANUAL FOR INSTALLATION
AND USER MANUAL

GB

ENGLISH

v.007 September 2008

Telair

Via E. Majorana , 49 48022 Lugo (RA) ITALY

“CE” DECLARATION OF CONFORMITY

in compliance with EC Machine Directive 89/392, appendix II A

It is hereby declared that the air conditioner specified below has been designed and built in compliance with essential safety and health requisites as per the European Directive on Machine Safety.

This declaration is rendered null and void in the event of incorrect assembly, improper use or modifications made to the machine without our written approval.

Machine: AIR CONDITIONER

Model: SILENT 7300 H

Serial n°

Reference directive:

Machine Directive (89/392/EEC), version 91/31/EEC

Low Voltage Directive (73/23/ EEC).

Electromagnetic compatibility (89/336/EEC), version 93/31/EEC.

Applied harmonised standards, especially: EN 292-1; EN 292-2; EN 60204-1.

DATE11/09/2008.....

C.E.O.



CONTENTS

1	INTRODUCTION	page 4
1.1	Purpose and field of application of the manual	page 4
1.2	Key to symbols and definitions	page 4
1.3	General information	page 4
2	IDENTIFYING THE AIR CONDITIONER	page 5
2.1	Components	page 5
2.2	ID plate	page 5
2.3	Technical specifications	page 6
3	TRANSPORT, HANDLING AND STORAGE	page 6
3.1	Storage	page 6
3.2	Weight	page 6
3.3	Handling	page 6
4	INSTALLATION	page 6
4.1	Preliminary information	page 6
4.2	Installation	page 7
4.2.1	Using the existing ventilation port	page 7
4.2.2	Opening a new hole	page 8
4.2.3	Power lead	page 8
4.3	Positioning the air conditioner	page 9
4.4	Connecting the power lead	page 10
4.5	Installing the diffuser	page 11
5	INSTRUCTIONS FOR USE	page 11
5.1	Introduction	page 11
5.2	Preliminary checks	page 12
5.3	Useful tips	page 12
5.4	Inserting the batteries in the remote control	page 12
5.5	Information on the remote control	page 13
5.6	Remote control key definitions/functions	page 13
5.7	Remote control display	page 14
5.8	Automatic mode	page 14
5.9	Conditioning mode	page 14
5.10	Heating mode	page 14
5.11	Diffuser display	page 15
5.12	Cleaning the filters	page 15
6	SAFETY REGULATIONS	page 15
7	TROUBLESHOOTING	page 16
8	DISPOSAL	page 16
9	MAINTENANCE	page 17
9.1	Routine maintenance	page 17
GENERAL TERMS OF WARRANTY		page 18
WIRING DIAGRAM		page 19
SPARE PARTS LIST		page 20

1 INTRODUCTION



Always consult this manual carefully before carrying out any work on the conditioner.

1.1 Purpose and field of application of this manual

This manual has been drawn up by the manufacturer in order to provide all the information / instructions needed for proper, safe use and maintenance of the air conditioner.

The manual is an important part of the air conditioner: it must be stored safely and kept in good condition throughout the working life of the machine and protected from deterioration. It must accompany the air conditioner if re-installed on a new vehicle or sold.

The information contained in this manual is intended for air conditioner installers and all those involved in its use and maintenance.

The manual defines the purpose for which the conditioner has been built and contains all the information required for its safe, correct use.

Constant observance of the information it contains will ensure user safety, low running costs and a longer air conditioner life.

To make consultation easy the manual is divided into sections, each of which deals with a specific topic. To find information quickly refer to the table of contents.

Information of particular importance is highlighted in bold type and accompanied by information/warning symbols (see following key).

You are strongly advised to read the entire manual and the reference documents: this is the best way to ensure long-lasting performance, reliability and prevention of injury or damage.

Note: *the information contained in this publication was correct at the time of going to press. Information may be modified without prior notice.*

1.2 Key to symbols and definitions

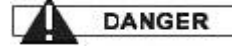

Indicates risk of serious injury or death and that the utmost care must be taken.

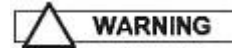

Situation that might arise during the working life of a product, system or plant which could cause harm, injury, damage to property or environment or result in additional expenses.

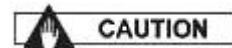

Indicates that it is necessary to proceed with due care and attention to prevent serious damage to material goods or resources such as the product itself.

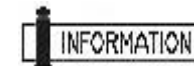

Indicates important information

Drawings are illustrative only. You may find that the illustrations differ from the machine in your possession: this does not in any way affect the validity of the general / safety information given in the manual.

As part of its product development and upgrade policy, the manufacturer reserves the right to make modifications without prior notice.

1.3 General information

The **SILENT 7300 H** air conditioner has been designed for installation on vehicle roofs. It runs on a 230 Vac 50 Hz power supply.



Power supply voltage must never drop below 210 Vac and frequency must be stable at 50 Hz.

Using the air conditioner at voltages other than those indicated could compromise its efficiency and damage the unit.

2 IDENTIFYING THE AIR CONDITIONER

2.1 Components (fig. 1)

- 1 Ventilation grille
- 2 Upper cover
- 3 Machine body
- 4 Technical specifications label
- 5 Connector duct
- 6 Air/conditioner block tunnel
- 7 Diffuser
- 8 Adjustable air outflow vents
- 9 Ambient air intake grille
- 10 Machine display
- 11 Removable air filter
- 12 Remote control

2.2 ID plate

- 1 Model
- 2 Serial number
- 3 Type of electrical power
- 4 Cooling capacity
- 5 Heating capacity
- 6 Type and quantity of coolant gas
- 7 Air flow rate
- 8 Absorbed power, cooling
- 9 Absorbed power, heating
- 10 Protection rating
- 11 Machine weight
- 12 Production date

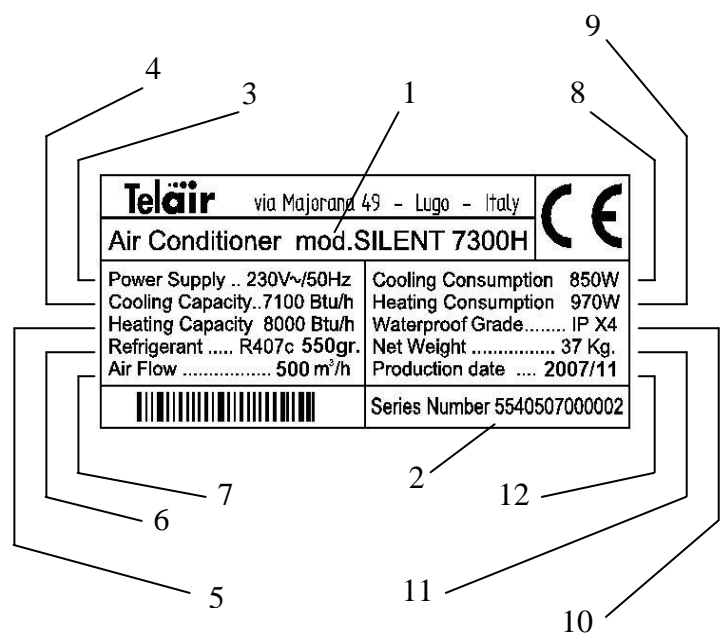
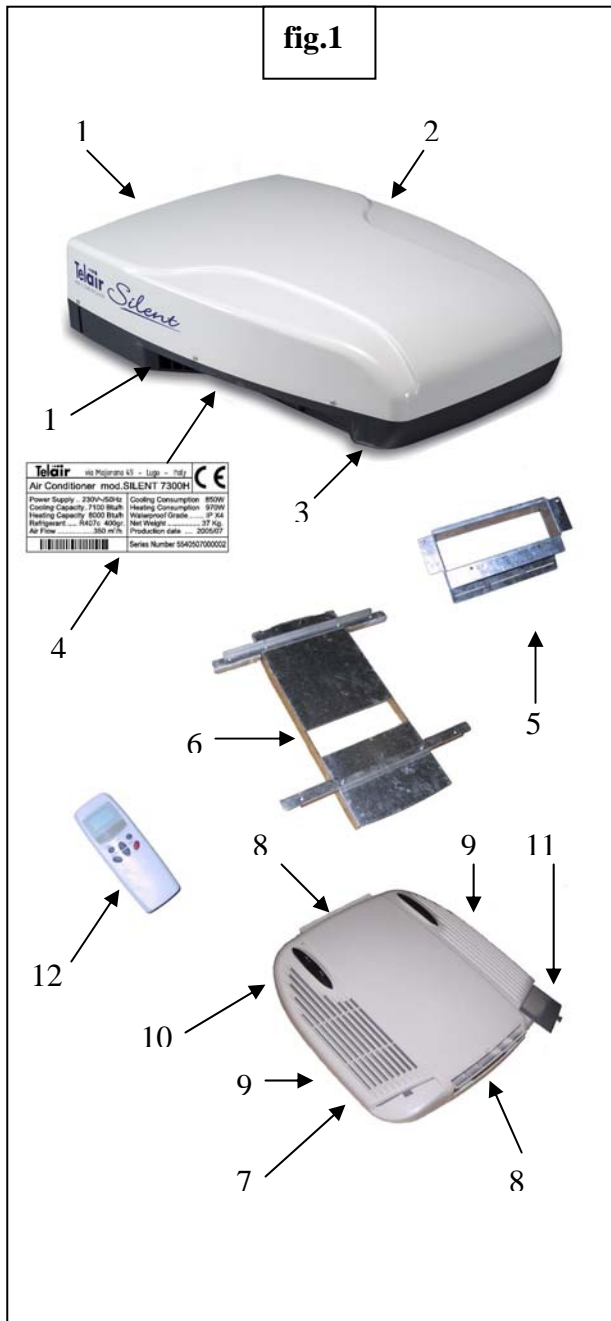

2.3 Technical specifications

SILENT 7300 H	
Power supply	230 V 50 Hz
Consumption	4.5 Ampere
Peak current	18 A (0.15 sec.)
Absorbed power, cooling	850 Watt
Absorbed power, heating	970 Watt
Cooling capacity	7100 Btu/h
Heating capacity	8000 Btu/h
Type and quantity of coolant gas	R 407c ... 550 gr.
N° of fan speeds	3
Air flow rate	500 m3/h
Waterproof rating	IP X4
Generator required	2200 W
Diffuser dimensions (H x L x W)	6.3x52.3x51 cm
Monobloc dimensions (H x L x W)	21.5x98x65 cm
Weight	37 Kg

3 TRANSPORT, HANDLING, STORAGE

3.1 Storage

During transport the air conditioner is protected by its cardboard packaging. The conditioner must be stored indoors in a horizontal position in a dry, ventilated area. The type of packaging allows up to 5 (five) conditioners to be stacked on top of each other.



CAUTION

Do not turn the package upside-down. The right way up is indicated by the symbol on the packaging (↑↑).



DANGER

Stacking more than five packaged air conditioners can damage the conditioners themselves and put personnel at risk of injury.

3.2 Weight

Weight, packaging excluded:
SILENT 7300 H 37 kg

3.3 Handling

Packaged air conditioners can be moved using standard means of lifting and transport. The packs have spacers for insertion of transpallet forks.



DANGER

Always observe safety and accident prevention regulations when lifting and transporting. Use only lifting and transport gear of a load bearing capacity greater than the weight to be lifted.

4 INSTALLATION

4.1 Preliminary information



INFORMATION

Before installing the conditioner you must read these instructions thoroughly to prevent errors.



WARNING

Incorrect installation can irreparably damage the air conditioner and compromise user safety.

European Machine Directive 89/392/EEC states that the manufacturer cannot be held liable for poor air conditioner performance and/or safety should the air conditioner fail to be installed in observance of the information provided in this manual. Moreover, the manufacturer cannot be held liable for any resulting injury or damage.



DANGER

Installation must only be carried out by qualified, specially trained personnel.

4.2 Installation



WARNING

Before installing the unit all the following electrical connections on the vehicle must be disconnected.

- Positive battery lead.
- Generator (where applicable).
- Outdoor power socket.



DANGER

Failure to observe the above can lead to power discharges.



DANGER

Before climbing on top of the vehicle check that the roof is designed to be walked on. Check with the vehicle fitter. If it is not, a scaffolding-like framework will be required.

To ensure proper air conditioner installation it is essential that you first check whether the roof is able to support its weight; if it is not the roof must be reinforced. Select a fairly flat, horizontal, central area of the roof and check that there are no obstacles in the interior which might obstruct diffuser attachment (**fig. 1 ref. 4**) or the outflow of cool air from the adjustable vents (**fig. 1 ref. 5**).

The air conditioner may be installed in one of two different ways:

- by using a ventilation aperture already on the vehicle (ventilation port)
- by opening a new hole.

4.2.1 Using the existing ventilation port.

This solution is practical as long as the port size is 400 x 400 mm (**fig. 2**). Figure 2 gives the dimensions of the air conditioners and the holes needed for installation.

products available from specialised shops (**fig. 3 ref. 2**).

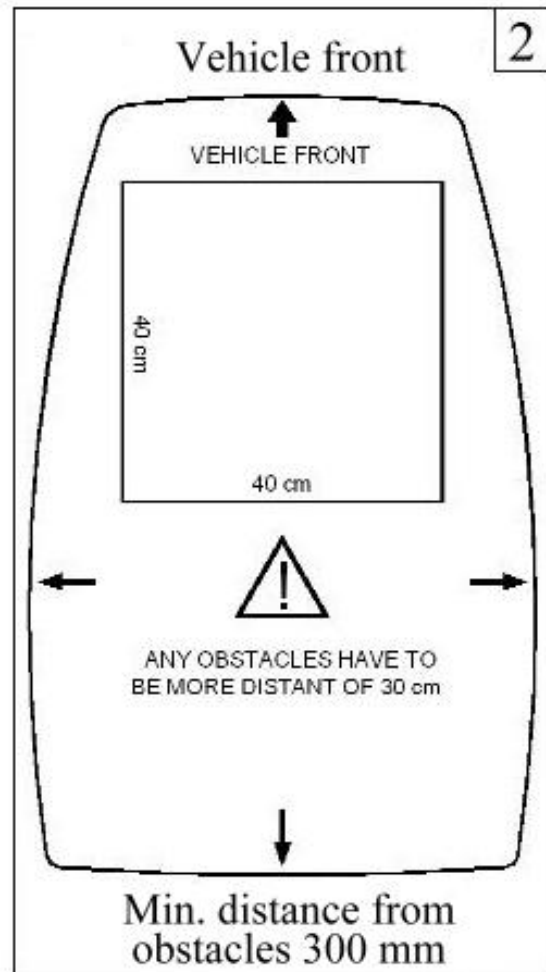

Proceed by removing the screws that fix the port to the roof and then removing the port itself.

Scrape off all the sealing material left around the rim of the opening (**fig. 3 ref. 1**) and putty screw holes and joints with silicon or other



All waste materials (glue, silicon, seals) must be placed in special containers and taken to official waste disposal centres.

4.2.2 Opening a new hole

Choose a central area of the roof between two side members and trace the outline of a 395 mm square with a felt-tip pen (fig. 2 ref. A) (fig. 4 ref. 1).

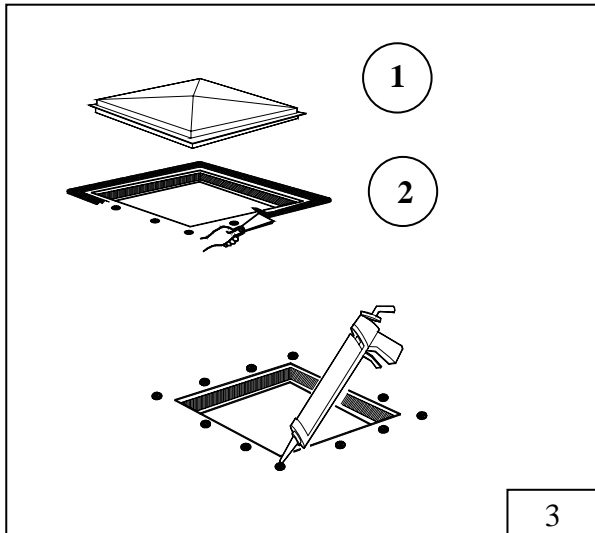

Cut the new opening in the roof carefully with a saw: be careful not to cut any electrical wires (fig. 4 ref. 2).

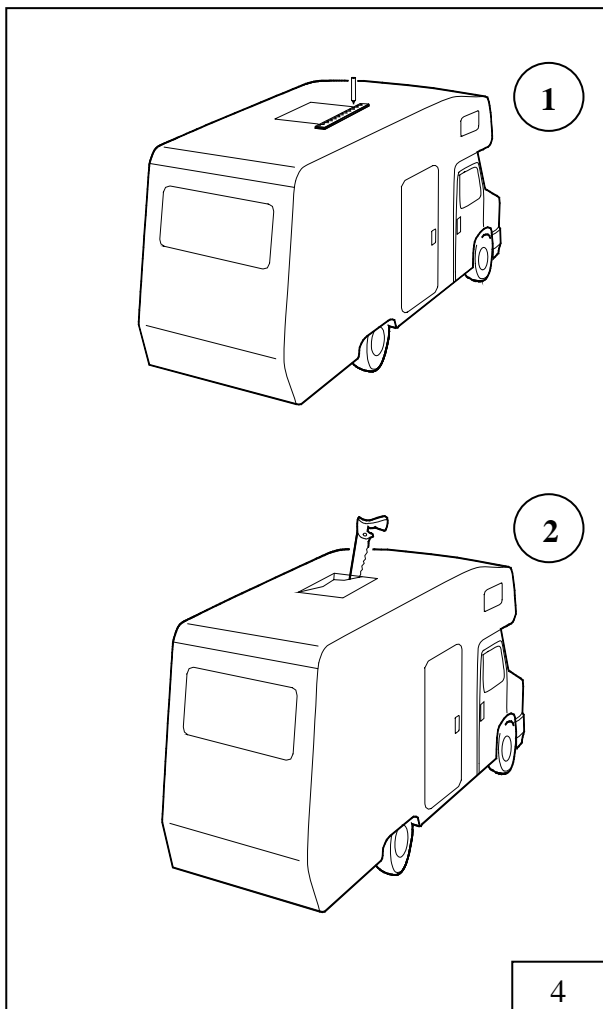

Fix a reinforcement frame around the opening (fig. 5).

CAUTION Use protective gloves and goggles before using electrical tools or handsaws.

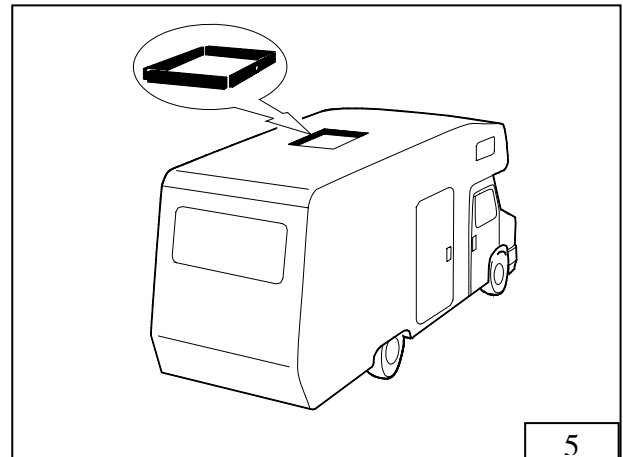

4.2.3 Power lead

To power the air conditioner it is necessary to lay a 3-pole lead (phase-neutral-earth): each wire must have a **minimum cross-section of 2.5 mm²**. At one end the lead must be connected to a **thermomagnetic switch** inside the electrical distribution board of the vehicle; the other end must reach the aperture on the roof, protruding from the hole on the reinforcement frame by about 50 cm: this additional length makes it easier to connect up to the air conditioner (fig. 6).

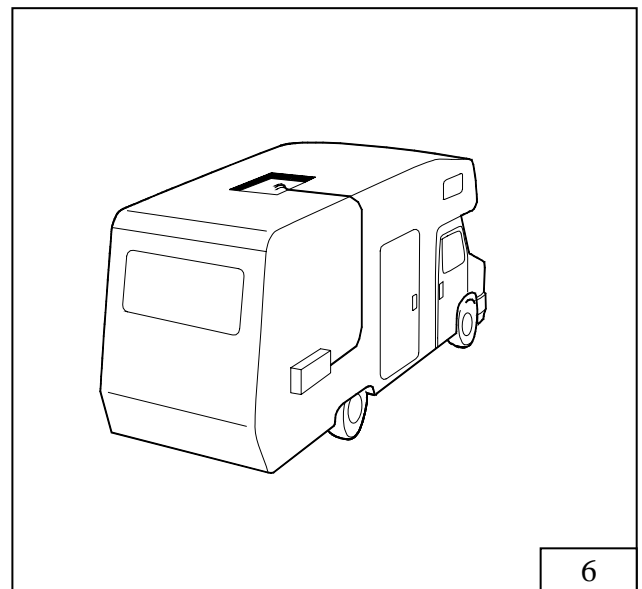

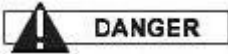

DANGER Before making any electrical connections always make sure the power is disconnected inside the distribution board and that the wire ends are not live.

It is compulsory for the air conditioner to be powered via a separate line protected by a **10 A thermomagnetic switch**.

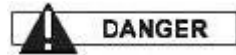

DANGER To ensure good insulation under all possible conditions electrical wiring must be properly sheathed.

4.3 Positioning the air conditioner

Before positioning the air conditioner on the vehicle roof it is necessary to lay a sufficient amount of slow-drying sealant around the rim of the aperture.

Bring the air conditioner onto the roof (fig. 7 ref. 2) and, **without scraping it**, position it over the 400 x 400 mm opening previously lined with sealant. Correct alignment of the air conditioner on the roof will provide a view - from inside the camper - of the 4 threaded fixing seats.

The arrow in fig. 7 indicates direction of forward drive.



INFORMATION The framed perimeter support seal must be aligned with the edge of the hole (fig 7 ref. 1).

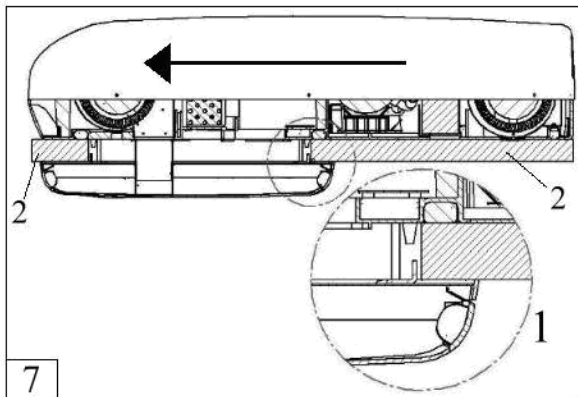

Working from inside the vehicle, shift the air conditioner until the four fixing threads are aligned with the square 400 x 400 mm opening of the hole on the roof.

Line the four external sides of the connecting duct with adhesive insulating tape so that it adheres to the folded fixing edge (fig. 8).

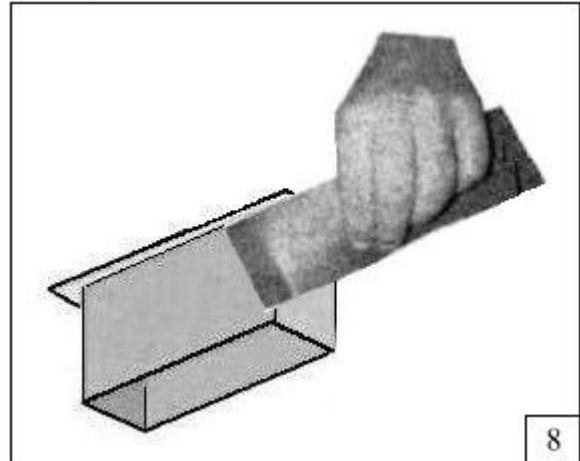

Working from inside the camper, insert the connection duct at the base of the air conditioner; use the four self-tapping screws L.12 mm (supplied). Align the duct with the rectangular hole of the ventilator (fig. 9). The arrow in figure 9 indicates the direction of forward drive.

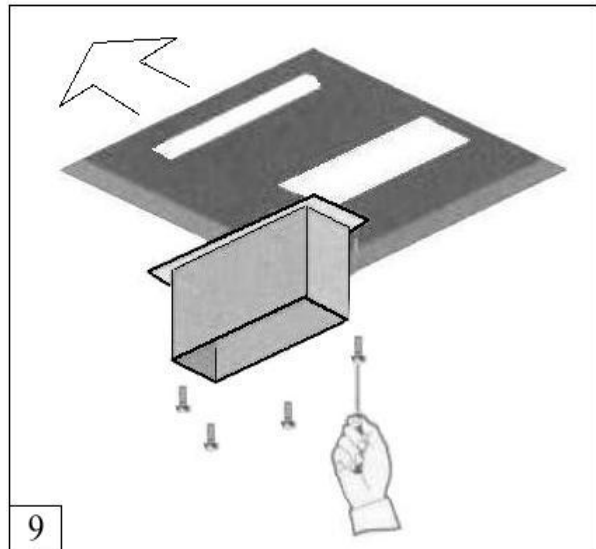

Fit the air/block tunnel with the supplied screws (fig. 10).

It is important to attach the screws according to a **driving torque of 2 Nm**, that is, **0.2 kgm**.

You are advised to use a torque wrench.

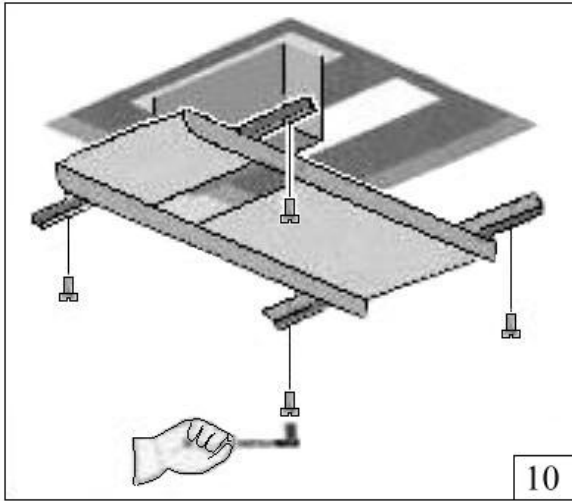

WARNING

Incorrect tightening can damage the support base of the air conditioner, compromise the seal and cause loud noise inside the vehicle when the conditioner is in operation.

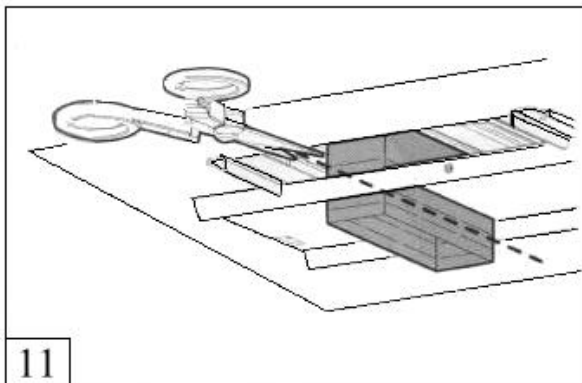

Cut the two sides of the connector duct (fig. 11) so that they do not protrude from the tunnel edge.

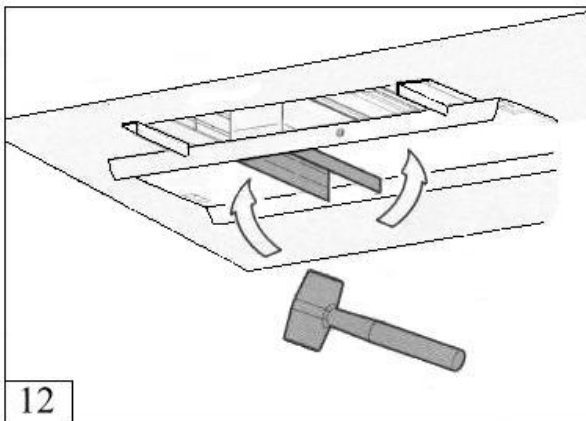

Fold the two long sides of the connector duct (fig. 12) so that they are horizontally in contact with the horizontal surface of the tunnel.

The resulting connection is shown in Fig.13.

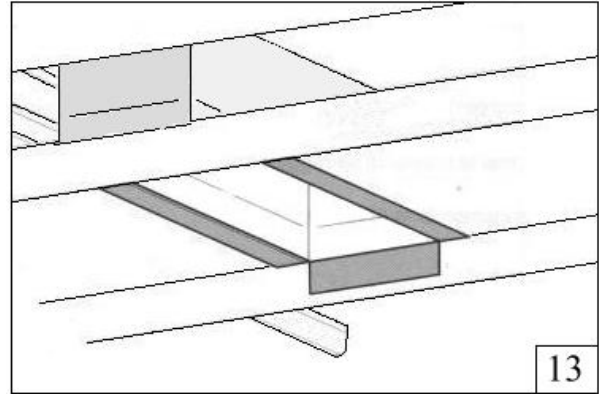

4.4 Connecting the power lead

Connect the 230 Vac power lead to the one on the just-installed conditioner (fig. 14).

Observe the wire colours:

- blue wire: neutral**
- brown wire: phase**
- yellow-green wire: earth ()**

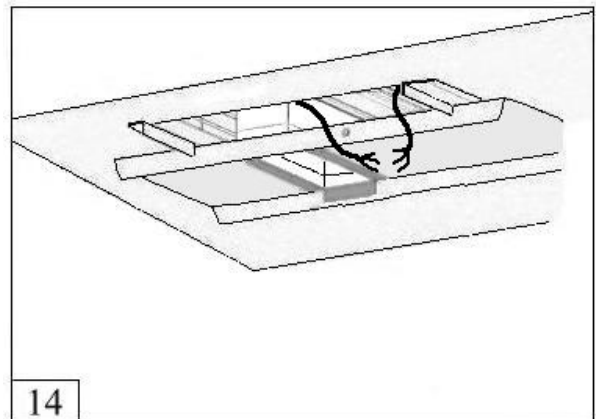

Check that the power lead is not excessively long as it could obstruct the intake grilles.

4.5 Installing the diffuser

Remove the two adjustable airflow director fins from the diffuser (fig. 15)

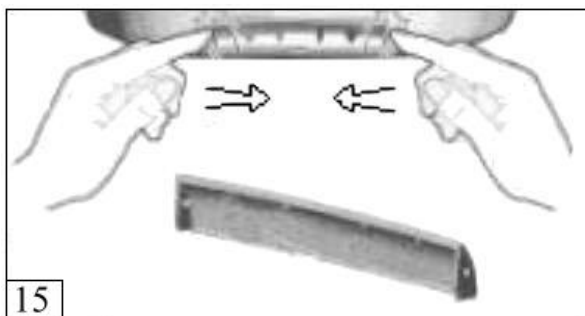

Connect up the panel coupling (Fig. 16) and fasten the diffuser with the 4 self-tapping screws L. 25 mm (fig. 17)

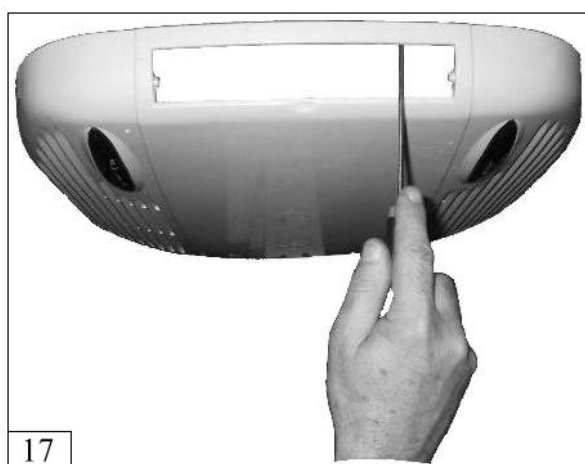
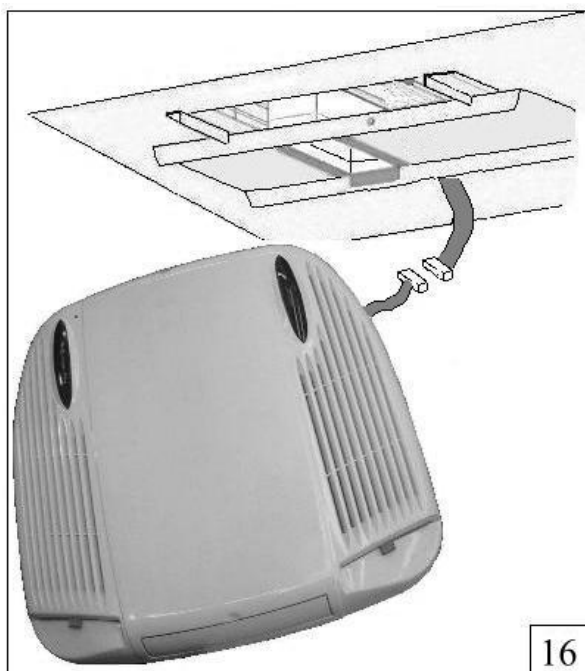

Then re-insert the two airflow director fins.



Note that, on first start-up, fans will start after 3 minutes and the air conditioner after a further 3 minutes.

5 INSTRUCTIONS FOR USE

Introduction



The manufacturer cannot be held liable for damage caused by improper use of the air conditioner.

The **SILENT 7300H** air conditioner consists of nine main parts:

- **compressor**, which circulates the coolant gas through the system.
- **condenser**, which cools the coolant by changing it from a gaseous to a liquid state.
- **evaporator**, which, cooled by the change of state of the coolant, cools the air passing through it.
- **fans**, which move the air so that it passes through the condenser and evaporator
- **solenoid valve**, which switches gas circulation and so provides a cooling or heating function
- **remote control** to program the desired function
- **receiver**, situated in the diffuser, which receives the remote control signals
- **electronic board**, which receives the signals from the receiver and transforms them into commands for the various electrical components of the air conditioner.

The **SILENT 7300H** provides cold air during the summer months and hot air in winter. If the vehicle has been left in the sun for some time it is good practice to open windows and doors before starting the conditioner so as to release the build up of heat in the interior; once indoor temperature matches outdoor temperature close the windows and doors and start the air conditioner. Subsequently, only open doors and windows when necessary.

5.2 Preliminary checks

Before switching on the air conditioner for the very first time:

- Check that condensate drainage holes are unobstructed.
- Check that power voltage and frequency are as indicated in the previous section.
- Check that air flow through relative ducts and vents is unobstructed. To ensure maximum efficiency always keep external ventilation grilles clear.

5.3 Useful tips

- Enhance the thermal insulation of the camper by eliminating any fissures and covering glass surfaces with heat-reflecting curtains.
- Avoid frequent opening/closing of windows unless necessary.
- Select a suitable temperature and airflow rate.
- Adjust the outflow vents to maximise comfort.
- Never close both adjustable vents when the conditioner is running.
- Wait at least 2 minutes between switching off and switching on so as not to damage the compressor.
- Clean the diffuser filters periodically; wash them with a detergent solution and dry them thoroughly before refitting them.
- Do not obstruct airflow inlets/outlets with fabric, paper or anything else.

- Do not spray water inside the air conditioner.
- Remove the remote control battery if you do not intend to use the conditioner for a long period.
- Periodically check that the condensate drain holes are not obstructed.
- Periodically check that external intakes grilles are clean so as to maintain maximum air conditioner efficiency.
- Clean the air conditioner with detergent solutions only; never use petrol or solvents.

5.4 Installing batteries in the Remote Control

1. Remove the cover by sliding it in the direction indicated by the arrow.



2. Insert two new 1.5 V AAA batteries: observe polarity (+ and -).



3. Replace the cover.



5.5 Information on the Remote Control

- Point the remote control towards the internal unit of the conditioner.
- There must be no obstructions between the remote control and the internal unit.
- Do not drop or throw the remote control.
- Do not expose the remote control to direct sunlight or leave it near heating systems or other sources of heat.
- Use two AAA batteries.
- If you do not intend to use the remote control for some time, remove the batteries.
- When the signal transmission noise is no longer audible inside the unit or when the transmission symbol on the display screen is no longer clearly visible, the batteries need replacing.
- If the unit resets when a control key is pressed battery power is too low: change the batteries.

Fan speed Allows the user to select one of the three available fan speeds.

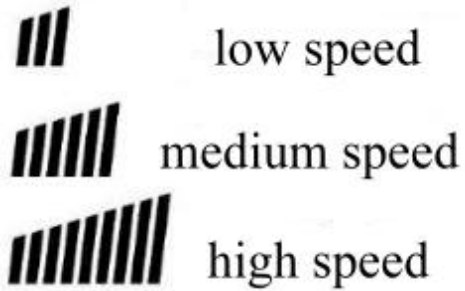

WARNING When the air conditioner is switched on 3 minutes will pass before the compressor is started and cold/hot air begins to flow from the diffuser.

5.6 Remote control key definitions/ functions

On/Off Press this key to start the air conditioner; press it again to switch it off.

Mode Allows the user to select the working mode: each touch of the key changes the mode.
The display shows the following:

Display Shows working mode and the fan speed setting (fig. 19)

Temperature increase Press this key to increase the temperature setting

Temperature decrease Press this key to lower the temperature setting

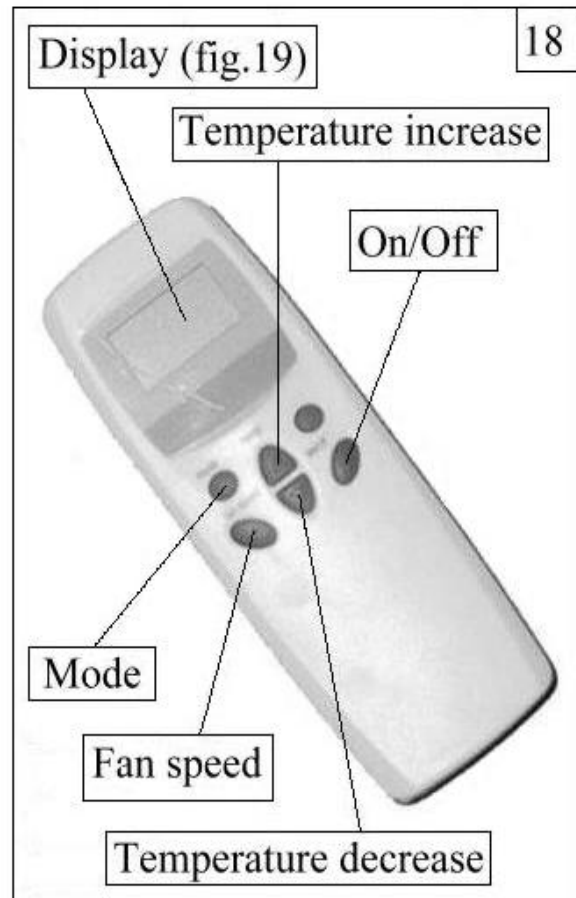

INFORMATION

Wait at least 2 minutes between switching off and subsequent switching on so as not to damage the compressor.

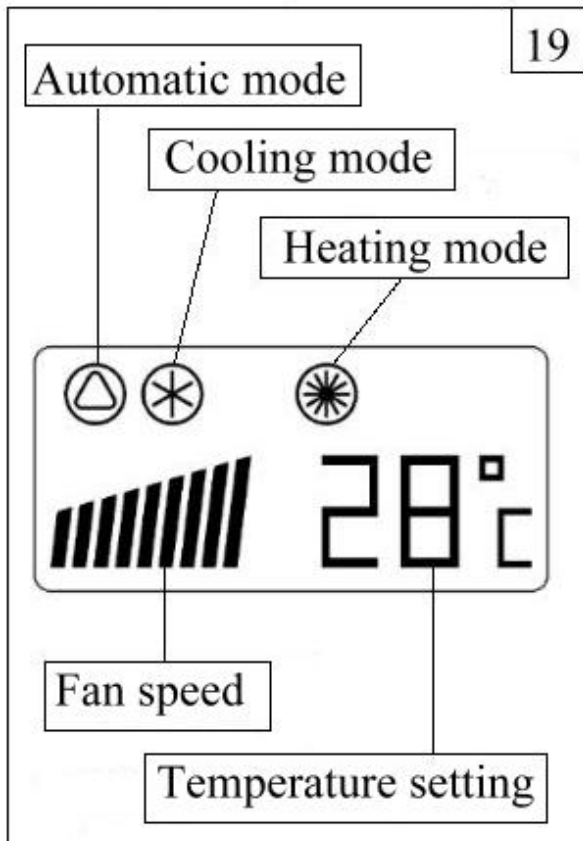
5.7 Remote control display (fig. 19)**5.8 AUTOMATIC mode**

- 1) Press the **On/Off** key.
- 2) Press the **Mode** key repeatedly until the display shows the **Automatic** symbol .
- 3) Select the desired temperature using the **Increase temperature** or **Decrease temperature** keys.
- 4) Press the **Fan speed** key repeatedly until the desired fan speed appears.

5.9 Cooling mode

- 1) Press the **On/Off** key.
- 2) Press the **Mode** key repeatedly until display shows the **Conditioning** symbol .
- 3) Select the desired temperature using the **Increase temperature** or **Decrease temperature** keys.
- 4) Press the **Fan speed** key repeatedly until the desired fan speed appears.

5.10 Heating mode

- 1) Press the **On/Off** key.
- 2) Press the **Mode** key repeatedly until the display shows the **Heating** symbol .
- 3) Select the desired temperature using the **Increase temperature** or **Decrease temperature** keys.
- 4) Press the **Fan speed** key repeatedly until the desired fan speed appears.

INFORMATION

If the air conditioner shuts down when in heating mode the fan will continue running for several minutes to disperse the heat accumulated inside the conditioner itself. The fans then shut down automatically.

INFORMATION

A flashing Fan Speed symbol on the display indicates that no speed has been chosen.

5.11 Diffuser Display

The diffuser has a display which also incorporates the remote control receiver.

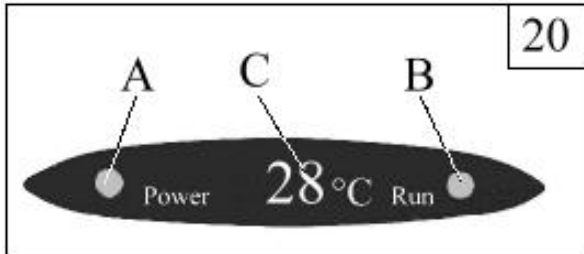

When the red light (**Fig. 20 ref. A**) next to the legend "Power" is on the air conditioner is powered by the 230 Vac power supply.

When the green light (**Fig. 20 ref. B**) next to the legend "Run" is on the air conditioner is working in the conditioning mode; if, instead, the red light (**Fig. 20 ref. B**) next to the legend "Run" is on the air conditioner is working in the heating mode.

The display also shows two numbers (**Fig. 20 ref. C**) that indicate temperature.

While you are selecting the desired temperature via the remote control the diffuser display will show the temperature selected at that moment.

About a minute after the end of selection, and during the entire time the conditioner is running, the display indicates the current in-camper temperature.

5.12 Cleaning the filters

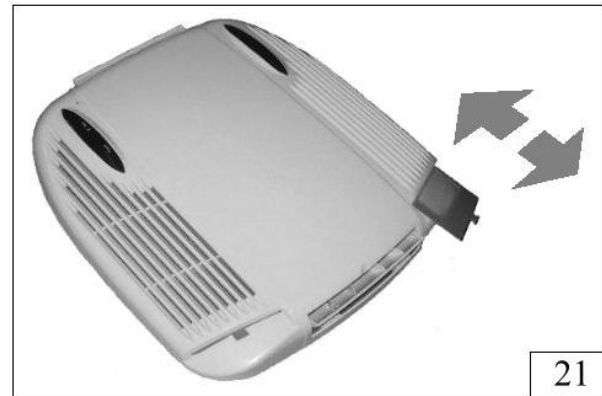

Periodically clean both diffuser filters: wash with a neutral detergent only and dry them thoroughly before putting them back in their seats (**fig. 21**).

6 SAFETY REGULATIONS

- Always use properly earthed power sockets with differential safety switches.
- Never use the air conditioner near flammable liquids.
- Do not use the air conditioner for purposes other than those stated by the manufacturer.
-
- Do not modify or tamper with any parts of the air conditioner.
- Use only original spare parts.
- Maintenance and repairs must only be carried out by specialised personnel.
- Installation must be carried out by qualified personnel.
- Keep children/animals away from the air conditioner unit.
- Do not insert hands/fingers in ventilation grilles/vents.
- Do not insert objects into ventilation intakes.
- If the air conditioner receives any hard knocks have it checked by specialised personnel before using it again.
- In the event of fire never open the upper cover of the conditioner: use homologated fire extinguishers.
- Do not attempt to put out a fire with water.

7 TROUBLESHOOTING

In the majority of cases poor air conditioner performance is caused by incorrect use as opposed to actual malfunctions. For example:

- The unit is too small for the volume of air you wish to condition.
- The vehicle is poorly insulated.
- The doors are opened too frequently.
- There are too many people inside the vehicle.
- Power supply voltage is less than 230 V.

There follows a list of the most common problems with relative cause and solution.

INFORMATION

Before inspecting for any other causes of poor air conditioner performance always check:

- the power supply, which must never be less than 205 V.
- that intake vents are unobstructed.
- that air outflow vents are open.

1) The air conditioner does not start:

- check that the remote control batteries are charged properly.
- check that the socket is providing power: check by connecting up any other appliance or use a voltmeter

2) Air outflow is insufficient:

- check that the directional vents are open enough
- check that the diffuser filters are clean enough

3) Air conditioning (cooling) is not working:

- check that temperature setting is lower than actual in-camper temperature.

4) Heating is not working:

- check that temperature setting is higher than actual in-camper temperature.

5) Air conditioner efficiency is poor

- if the air conditioner is working inefficiently it is necessary to clean the air filter, condenser and evaporator using specific detergents. It is always advisable

to clean the air conditioner when it has remained idle for a long period.

- if, after cleaning the exchangers, the air conditioner still fails to return to its initial level of efficiency, then the coolant gas load must be checked.

8 DISPOSAL

Always contact specialised workshops when it is necessary to dismantle and dispose of the air conditioner.



INFORMATION

Waste materials must not be dispersed into the environment: always take them to authorised waste collection centres

9 MAINTENANCE

9.1 Routine maintenance

All tasks requiring removal of air conditioner covers must – as with installation - be carried out by expert personnel



Before carrying out any work on the air conditioner it is essential that you disconnect the 230 V power supply and wait for all its component parts to cool down.

- Remove the external cover and spray a suitable detergent onto the heat exchangers (evaporator and condenser) and then rinse to remove impurities. Check that the condensate drain holes are unobstructed.
- Check that the seals are in good condition and there is no infiltration of water into the vehicle.
- All traces of oxidation must be removed and metallic parts coated with a suitable paint.
- Check that wiring insulation is in good condition and eliminate any traces of moisture.
- Check that all screws are properly tightened.
- If the vehicle is garaged for the winter disconnect the air conditioner from the power socket.

GENERAL TERMS OF WARRANTY

Telair guarantees that its products are without faults or defects in their material and/or construction.

The effects of the warranty are understood to be limited to the right to obtain replacement or repair free of cost of any part which should turn out to be defective, within 12 months from the date of purchase of the product and in **Telair's** opinion.

It is understood that the purchaser has no right whatsoever:

- to terminate the contract;
- to claim damages for people or things;
- to demand an extension of the warranty in case of any product defect or malfunction.

Any transport charges are on the account of the purchaser, as well as any expenses for on-site checks requested by the purchaser and accepted by **Telair**.

The warranty shall be valid only if the customer is able to show a document evidencing the date of purchase (invoice or receipt).

This document must be kept whole and must be submitted to the **Telair** after-sales centre when asking for operation under warranty.

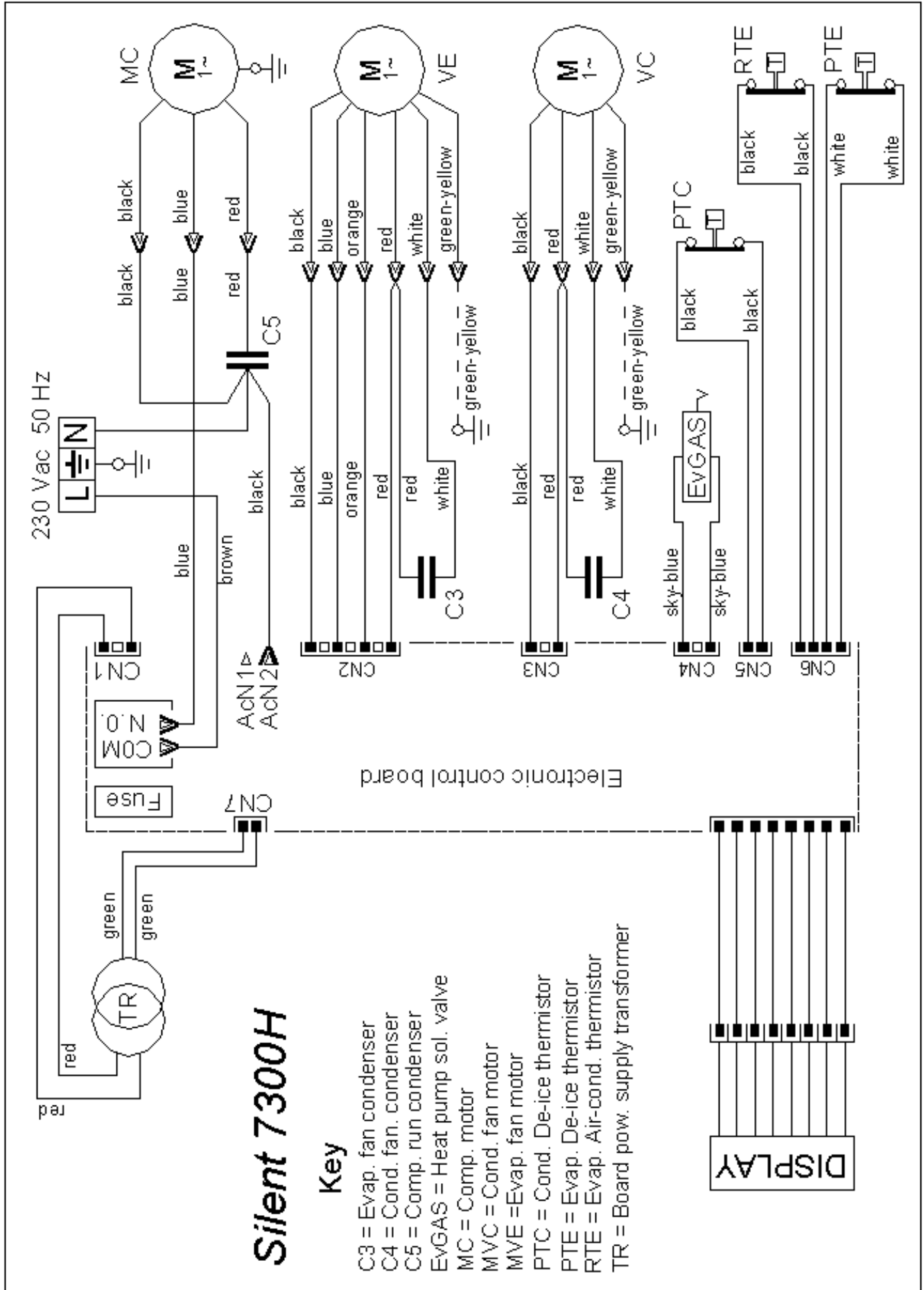

Silent 7300H

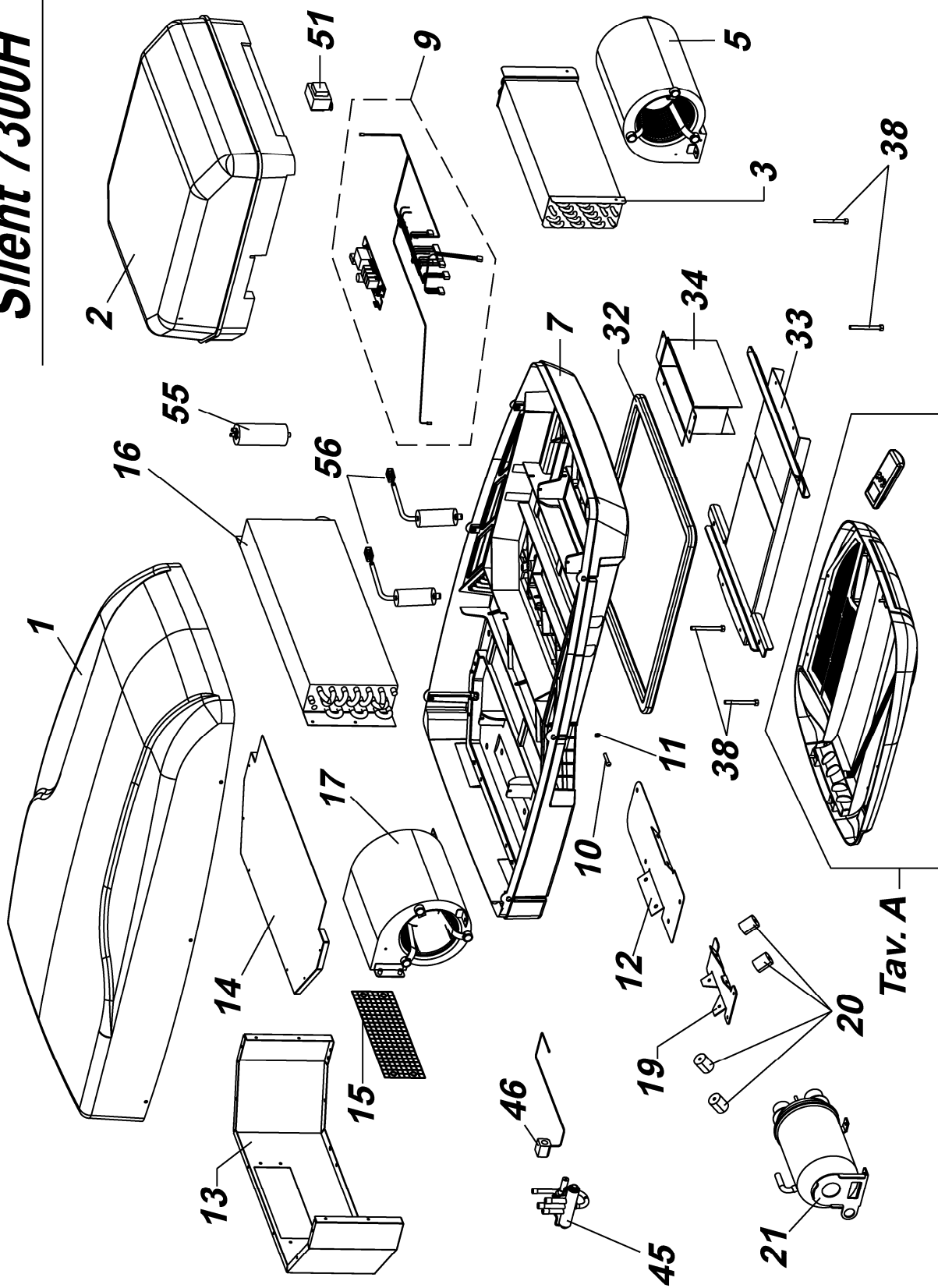

Silent 7300H

Tav. A

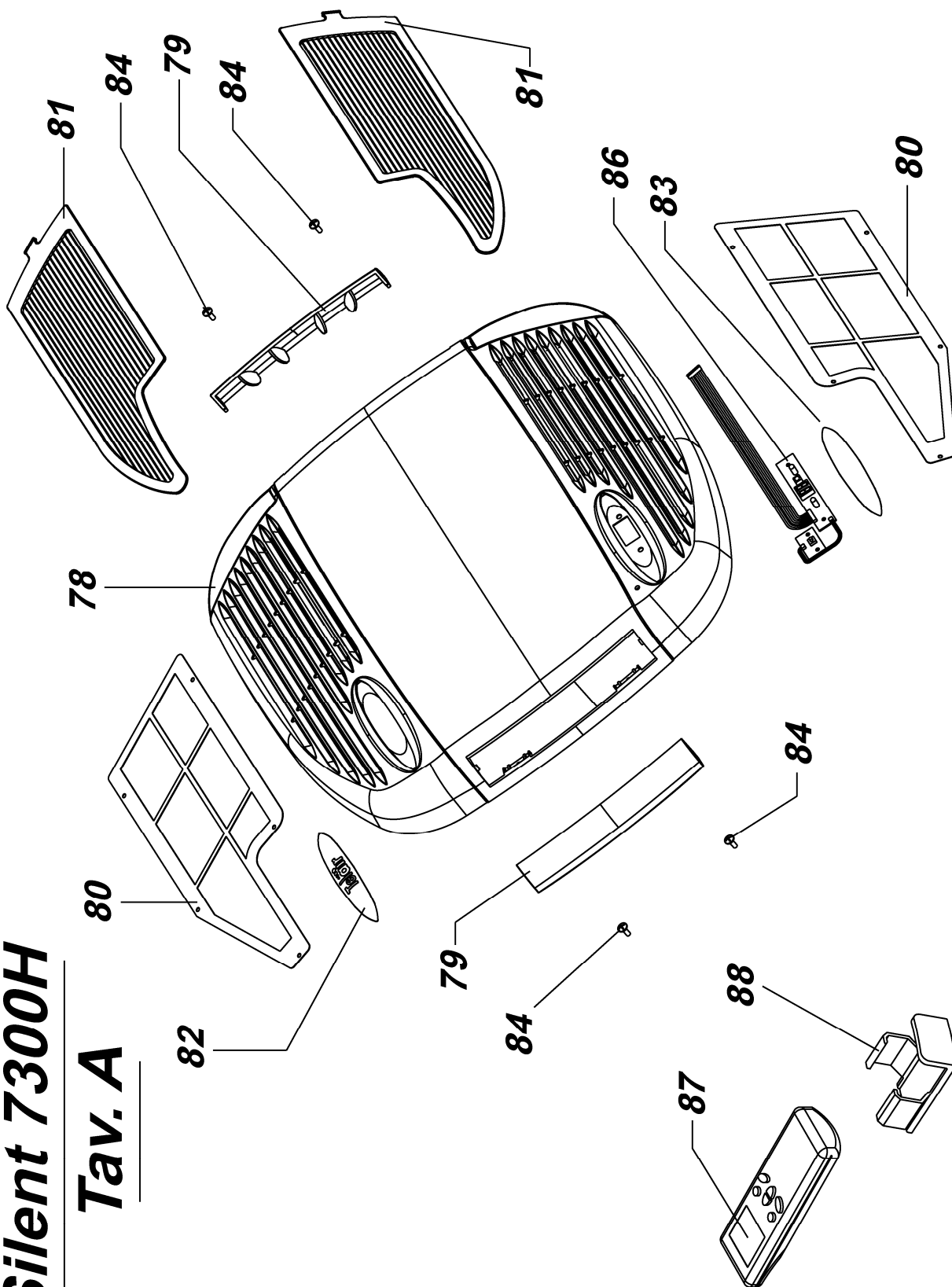

Pos./Code/Q.tà	Descrizione/Description	Désignation/Bezeichnung	Denomination/Descripcion
1 / 03476 / n. 1	Coperchio superiore in plastica Plastic top cover	Capot supérieur en plastique Oberer Deckel aus Kunststoff	Bovenste deksel van plastic Tapa superior de plástico
2 / 03493 / n. 1	Coperchio dell'evaporatore Evaporator cover	Couvercle de l'évaporateur Deckel des Verdampfers	Deksel van de verdamper Tapa del evaporador
3 / 03482 / n. 1	Evaporatore completo Complete evaporator	Évaporateur complet Verdampfer, komplett	Complete verdamper Evaporador completo
5 / 03919 / n. 1	Ventilatore centrifugo dell'evaporante Centrifugal fan of the evaporator	Ventilateur centrifuge de l'évaporateur Zentrifugallüfter des Verdampfers	Centrifugaalventilator van de verdamper Ventilador centrifugo del evaporador
7 / 03643 / n. 1	Fondo in plastica grigio antracite Anthracite grey plastic bottom	Fond en plastique gris anthracite Kunststoffbasis, Anthrazitgrau	Onderkant van plastic, antracietgrijs Fondo de plástico gris marengo
9 / 03944 / n. 1	Cablaggio elettrico completo Full electric wiring	Câblage électrique complet Verkabelung, komplett	Complete elektrische bedrading Cableado eléctrico completo
10 / 03378 / n. 6	Vite M 5X16 per fissaggio coperchio superiore Screw M 5X16 for top cover fastening	Vis M 5X16 pour fixation capot supérieur Schraube M 5X16 für Befestigung des oberen Deckels	Schroef M 5X16 voor bevestiging van bovenste deksel Tornillo M 5X16 para fijar la tapa superior
11 / 03500 / n. 6	Dado M5 per fissaggio coperchio superiore Nut M5 for top cover fastening	Écrou M5 pour fixation capot supérieur Mutter M5 für Befestigung des oberen Deckels	Moer M5 voor bevestiging van bovenste deksel Tuerca M5 para fijar la tapa superior
12 / 03485 / n. 1	Staffa per antivibranti per la base del compressore Vibration mount bracket for the compressor base	Bride pour disp. antivibrations pour base du compresseur Bügel für Schwingungsdämpfer für Kompressorbasis	Beugel voor trillingsdempers voor onderkant van de compressor Estribo para anti-vibrantes para la base del compresor
13 / 03478 / n. 1	Scatola del condensatore Condenser casing	Boîtier du condenseur Kondensatorgehäuse	Behuizing van de condensator Caja del condensador
14 / 03477 / n. 1	Coperchio del condensatore Condenser cover	Couvercle du condenseur Deckel des Kondensators	Deksel van de condensator Tapa del condensador
15 / 03503 / n. 1	Rete metallica Wire net	Grille métallique Metallgitter	Metalen rooster Red metálica
16 / 04198 / n. 1	Condensatore completo Complete condenser	Condenseur complet Kondensator, komplett	Complete condensator Condensador completo
17 / 03480 / n. 1	Ventilatore del condensatore Condenser fan	Ventilateur du condenseur Lüfter des Kondensators	Ventilator van de condensator Ventilador del condensador
19 / 03484 / n. 1	Staffa fissaggio compressore Compressor fastening bracket	Bride de fixation compresseur Befestigungsbügel für Kompressor	Bevestigingsbeugel voor de compressor Estribo de fijación compresor
20 / 03486 / n. 4	Antivibrante per la base del compressore Vibration mount for the compressor base	Disp. antivibrations pour base du compresseur Schwingungsdämpfer für Kompressorbasis	Trillingsdemper voor de onderkant van de compressor Anti-vibrador para la base del compresor
21 / 04197 / n. 1	Compressore rotativo Rotative compressor	Compresseur rotatif Rotationskompressor	Roterende compressor Compresor rotativo
32 / 03497 / n. 1	Guarnizione in gomma rotonda d=26 Round rubber gasket d=26	Joint en caoutchouc rond d=26 Rundgummidichtung D=26	Ronde rubber afdichting d=26 Guarnición de goma redonda d=26
33 / 03499 / n. 1	Tunnel fissaggio condizionatore Air-conditioner fastening tunnel	Goulotte de fixation climatiseur Befestigungstunnel für Klimaanlage	Bevestigingstunnel voor airconditioner Túnel de fijación acondicionador

Pos/Code/Q.tà	Descrizione/Description	Désignation/Bezeichnung	Denomination/Descripcion
34 / 03498 / n. 1	Condotta uscita aria dall'evaporatore Duct for air outlet from evaporator	Conduite de sortie de l'air de l'évaporateur Luftausgangskanal aus Verdampfer	Luchtuitlaatkanaal uit de verdampfer Conducto salida aire del evaporador
38 / 05522 / n. 4	Vite di fissaggio M6x100 Fastening screw M6x100	Vis de fixation M6x100 Befestigungsschraube M6x100	Bevestigingsschroef M6x100 Tornillo de fijación M6x100
45 / 03337 / n. 1	Elettrovalvola 4 vie DSF - 4/230 V 4-way solenoid valve DSF - 4/230 V	Électrovanne 4 voies DSF - 4/230 V 4-Wege-Magnetventil DSF - 4/230 V	4 - weg elektromagneetklep DSF - 4/230 V Electroválvula de 4 vías DSF - 4/230 V
46 / 03475 / n. 1	Bobina x elettrovalvola 4 vie Coil for 4-way solenoid valve	Bobine pour électrovanne 4 voies Spule für 4-Wege-Magnetventil	Spoel voor 4-weg elektromagneetklep Bobina para electroválvula de 4 vías
51 / 02487 / n. 1	Trasformatore per impianto elettrico Transformer for electric system	Transformateur pour circuit électrique Transformator für Elektroanlage	Transformator voor elektrische installatie Transformador para instalación eléctrica
55 / 03504 / n. 1	Condensatore 15 uF 450 V Condenser 15 uF 450 V	Condensateur 15 uF 450 V Kondensator 15 uF 450 V	Condensator 15 uF 450 V Condensador 15 uF 450 V
56 / 03505 / N. 2	Condensatore 3 uF 450 V Condenser 3 uF 450 V	Condensateur 3 uF 450 V Kondensator 3 uF 450 V	Condensator 3 uF 450 V Condensador 3 uF 450 V
78 / 03511 / n. 1	Diffusore interno Indoor diffuser	Diffuseur interne Innendiffusor	Inwendige stromingsspreider Difusor interno
79 / 03512 / n. 2	Aletta per diffusore interno Fin for indoor diffuser	Ailette pour diffuseur interne Rippe für Innendiffusor	Lamel voor inwendige stromingsspreider Aleta para difusor interno
80 / 03509 / n. 2	Cornice portafiltro antipolvere Dust filter holding frame	Cadre porte-filtre anti-poussière Staubfilter-Tragrahmen	Draagprofiel voor stoffilter Marco portafiltro anti-polvo
81 / 03510 / n. 2	Filtro antipolvere Dust filter	Filtre-antipoussière Staubfilter	Stoffilter Filtro anti-polvo
82 / 03492 / n. 2	Coperchio trasparente con logo Telair Transparent cover with Telair logo	Couvercle transparent avec logo Telair Transparenter Deckel mit Telair-Logo	Doorzichtige deksel met Telair logo Tapa transparente con logo Telair
83 / 03491 / n. 2	Coperchio trasparente del display Transparent display cover	Couvercle transparent pour afficheur Transparenter Displaydeckel	Doorzichtige displayafdekking Tapa transparente del display
84 / 03409 / n. 4	Vite 3,5x25 per fissaggio diffusore Screw 3.5x25 for diffuser fastening	Vis 3,5x25 pour fixation diffuseur Schraube 3,5x25 für Diffusorbefestigung	Schroef 3,5x25 voor bevestiging van de stromingsspreider Tornillo 3,5x25 para fijar el difusor
86 / 03489 / n. 1	Scheda elettrica del display Electric display board	Carte électrique de l'afficheur Displaykarte	Elektrische displaykaart Tarjeta eléctrica del display
87 / 03487 / n. 1	Telecomando Remote control	Télécommande Fernbedienung	Afstandsbediening Mando a distancia
88 / 03514 / n. 1	Porta Telecomando Remote control holder	Support de télécommande Fernbedienungshalter	Afstandsbedieningshouder Porta-mando a distancia

Foto e disegni non contrattuali - Les photos et les dessins ne sont donnés qu'à titre indicatif.
We reserve the right to make technical changes without prior notice - Fotos und Zeichnungen nicht vertraglich. Fotos y planos no indicados en contrato



Telair

AIR CONDITIONER

ITALY

Via E. Majorana 49
48022 LUGO (RA)
Tel. + 39 0545 25037
Fax. + 39 0545 32064

E-mail: telair@telecogroup.com
www.telecogroup.com

IN EUROPE:

GREAT BRITAIN - SCAN TERIEUR LTD
30, The Metro Centre, Tolpits Lane - Watford,
Herts - England - WD18 9XG
Tel. 01923 800353 - Fax 01923 220358

HOLLAND / BELGIUM - KARMAN TRADING
Lagewed 54 - 3849 PE Hierden - the Netherlands
Tel. 0341 722450 - Fax 0341 722451
e-mail: info@karmantrading.nl
web site: www.karmantrading.nl

FRANCE - BLEYS JEAN-PHILIPPE
19, Rue de la Parcheminerie
18700 Aubigny sur Nere - France
Tel. 02 48580367 - Fax 02 48583585
e-mail: bleys.teleco@club-internet.fr

ESPAÑA - NAUCCA CARAVANING, S.A.
Poligono Industrial CAN ROQUETA 2 - Calle Can Lletget, 2
08202 Sabadell (Barcelona) - España
Tel. 00 34 937 457 054 - Fax. 00 34 937 254 484
e-mail: comercial@naucca.com

ÖSTERREICH - TELECO GmbH
82041 Deisenhofen - Deutschland
Tel. 0049 8031 98939 - Fax. 0049 8031 98949
e-mail: telecogmbh@telecogroup.com
www.telecogroup.com

IN DEUTSHLAND

TELECO GmbH 
82041 Deisenhofen -
Tel. 0049 8031 98939 - Fax. 0049 8031 98949
e-mail: telecogmbh@telecogroup.com
www.telecogroup.com

Händler und Info in Ihrer Nähe (Deutschland):

01805 006857

Service für Teleco Anlagen in Deutschland:

09001000045

**KUNDENDIENST
BEI
AUSGEWÄHLTEN
BOSCH SERVICE!**

